

D7212GV2



Security Systems

EN | Operation and Installation Guide
Control Panel

BOSCH

Trademarks

CoBox™ is a registered trademark of Lantronix®.

Windows® is a registered trademark of Microsoft Corporation in the United States or in other countries.

Molex® is a registered trademark of Molex Incorporated.

Certifications and Approvals

The D7212GV2 Literature Pack includes the *D7212GV2 Approved Applications Compliance Guide*. Refer to this guide for additional guidelines on installing the control panels in Underwriters Laboratories Inc. (UL) and fire-specific applications.

Fire

UL

Underwriters Laboratories, Inc. (UL) lists the D7212GV2 Control Panel as a Control Unit for Household Fire Warning.



The D7212GV2 is not UL Listed for Commercial Fire (UL864).

Burglary

UL

UL lists the D7212GV2 Control Panel for: Central Station, Local, Police Connect, Bank Safe and Vault, Mercantile Safe and Vault, and Grade A Household Systems.

Federal Communications Commission (FCC) Rules

Part 15

This equipment was tested and found to comply with the limits for a Class A digital device, pursuant to Part 15 of the FCC rules. These limits are designed to provide reasonable protection against harmful interference when the equipment is operated in a commercial environment.

This equipment generates, uses, and can radiate radio frequency energy and, if not installed and used according to the instructions, can cause harmful interference to radio communications.

Operation of this equipment in a residential area is likely to cause harmful interference, in which case the user is required to correct the interference at his or her own expense.

Part 68

This equipment complies with Part 68 of FCC rules. A label contains, among other information, the FCC registration number and ringer equivalence number (REN). If requested, this information must be provided to the telephone company.

The D7212GV2 Control Panel is registered for connection to the public telephone network using an RJ38X or RJ31X jack.

The REN is used to determine the number of devices that can be connected to the telephone line. Excessive RENs on the telephone line may result in the devices not ringing in response to an incoming call. In most, but not all areas, the sum of the RENs should not exceed five. To be certain of the number of devices that can be connected to the line, as determined by the RENs, contact the telephone company to determine the maximum REN for the calling area.

If you experience trouble with the D712GV2 Control Panel, please contact Bosch Security Systems Customer Service for repair and warranty information. If the trouble is causing harm to the telephone network, the telephone company might request that the equipment be removed from the network until the problem is resolved. User repairs must not be made, and doing so will void the user's warranty.

If the D7212GV2 Control Panel causes harm to the telephone network, the telephone company attempts to notify you in advance. If advance notice is not practical, the telephone company notifies you as soon as possible. Also, you will be advised of your right to file a complaint with the FCC if you believe it is necessary.

The telephone company might make changes in its facilities, equipment, operations, or procedures that affect the operation of the equipment. If this happens, the telephone company provides advance notice in order for the necessary modifications to be made in order to maintain uninterrupted service.

This equipment cannot be used on public coin service provided by the telephone company. Connection to Party Line service is subject to state tariffs. (Contact your state public utilities commission for information.)

FCC Registration Number: AJ9MUL-46532-AL-E

Service Center in USA:

National Repair Center
130 Perinton Parkway
Fairport, NY 14450
(800) 289-0096

Ringer Equivalence: 0.4B

Contents

1.0	Introduction	6	4.9	Testing the System	18
2.0	Lightning Strikes	7	5.0	Power Supply	19
2.1	Effects.....	7	5.1	Primary Power Terminals 1 and 2	19
2.2	Precautions during Installation.....	7	5.1.1	Primary (AC) Power Circuit	19
3.0	Overview	8	5.1.2	Installing the Transformer.....	19
3.1	Configuration and Parts	8	5.2	Secondary Power Terminals	19
3.1.1	Parts List	9	5.2.1	Secondary (DC) Power	19
3.1.2	Parts Available by Separate Order.....	9	5.2.2	Installing the Battery	19
3.2	Accessories	10	5.2.3	Replacing the Battery	21
3.3	Features in the D7212GV2.....	11	5.2.4	Battery Supervision	21
3.3.1	SDI Molex Connector	11	5.2.5	Battery Charging Circuit	21
3.3.2	Tip and Ring Posts	11	5.2.6	Battery Discharge and Recharge Schedule ...	22
3.3.3	Super Capacitor	11	6.0	Power Outputs	24
3.3.4	Telephone Line Sniff.....	11	6.1	Circuit Protection	24
3.3.5	Points.....	11	6.2	Total Available Power	24
3.3.6	Areas and Accounts.....	11	6.3	Continuous Power Output Terminals 3, 8, and 32	24
3.3.7	Digital Communicator	11	6.4	Programmable Power Output Terminals 6, 7, and 8	24
3.3.8	Keypads	12	6.4.1	Programming	24
3.3.9	Keyswitch	12	6.4.2	Terminals 6 and 7	25
3.3.10	Event Memory	12	6.4.3	Fire System Power Formula.....	25
3.3.11	Event Log	12	6.4.4	Terminal 8.....	25
3.3.12	Ground Fault Detection	12	7.0	Telephone Connections	26
3.3.13	Ground Fault Detection Added Feature	12	7.1	Registration	26
3.3.14	Programming	12	7.2	Notification	26
3.3.15	Other Features	13	7.3	Location.....	26
4.0	Installation	14	7.4	Telephone Cord Connection	26
4.1	Installation Preparation.....	14	7.5	Phone LED (Red).....	27
4.2	Enclosure Options	14	7.6	Operation Monitor LED (Green).....	27
4.3	Mounting Enclosure	14	7.7	Dialing Format.....	27
4.4	Installing the Control Panel.....	15	7.8	Telephone Line Monitor	27
4.5	Connecting Earth Ground.....	15	7.9	Called Party Disconnect.....	27
4.5.1	Terminal 10.....	15	7.10	Communication Failure.....	27
4.5.2	Ground Fault Detect Enable	15	8.0	On-Board Points	28
4.5.3	Enabling Ground Fault Detection	16	8.1	Terminals 11 to 22 Description	28
4.5.4	D7212GV2 Ground Fault Specifications	16	8.2	Point Sensor Loops	28
4.5.5	Locking the Reset Pin	16	8.3	Point Parameters.....	28
4.6	Completing the Installation.....	17	8.4	Point Response Time	29
4.6.1	Charging the Battery	17	8.5	Wiring Information for Installations Using the Ademco AB-12 Bell/Housing	29
4.6.2	Installing and Wiring Detection Devices.....	17	9.0	Off-Board Points	31
4.6.3	Installing Modules and Relays.....	17	9.1	Point (Zonex) Bus: D7212GV2 Terminals	31
4.6.4	Connecting the On-board Points and Keypads	17	9.1.1	POPIT Modules	31
4.6.5	Powering Up	17	9.1.2	POPEX Modules.....	31
4.7	Programming the Control Panel.....	18	9.1.3	Missing Conditions	31
4.8	Installing the Point Chart Label.....	18	9.1.4	Extra Point Events.....	31

9.1.5	D7212GV2 Responses to Missing Point Conditions	32	12.4.2	Address Settings	49
9.2	D8125, D8127 and D9127 POPIT Modules	32	12.4.3	Supervision.....	49
9.3	Installing the D8125 POPEX Module	34	12.5	SDI Address 88.....	49
9.3.1	Mounting	34	12.5.1	D9133DC Direct Connect Programming Module	49
9.3.2	Wiring the D8125 to the Control Panel.....	34	12.5.2	Network Interface Modules	50
9.3.3	Wiring POPITs to the Data Expansion Loop.....	34	12.5.3	Address Settings	50
9.3.4	Wiring Data Expansion Loops to POPEX Modules	35	12.5.4	Supervision.....	50
9.3.5	POPIT Sensor Loops	35	13.0	Programmer Connections.....	51
9.3.6	POPIT Module Point Assignments	35	13.1	Programmer Connector.....	51
9.3.7	Program Record Sheet.....	35	13.2	Programmer Access Reports.....	51
9.3.8	POPIT Labels	36	14.0	D7212GV2 Faceplate	52
9.4	D8128D OctoPOPIT Module.....	36	Appendix A: System Wiring Diagrams, Issue A		53
9.4.1	Description	36	Appendix B: Point Address Chart.....		56
9.4.2	Listings	36	Specifications.....		58
9.4.3	Installation	37			
9.4.4	Setting the OctoPOPIT Switches.....	37			
9.4.5	Mounting OctoPOPITs.....	38			
9.4.6	Wiring OctoPOPITs.....	38			
9.4.7	OctoPOPIT Sensor Loops.....	41			
9.5	Testing Off-Board Points	41			
10.0	Off-Board Relays	42			
10.1	D8129 OctoRelay	42			
10.2	Configuring the D8129 OctoRelay	42			
10.3	Relay Outputs	43			
10.4	Installing OctoRelays	43			
10.5	Wiring Connections	43			
11.0	Arming Devices.....	44			
11.1	Description	44			
11.2	Keypad Terminals 29 to 32.....	44			
11.2.1	Assigning an Address for the Keypad.....	44			
11.2.2	Installation	44			
11.3	D268/D269 Independent Zone Control, D279A Independent Zone Control	46			
11.4	Keyswitch	46			
11.4.1	Description	46			
11.4.2	Programming	46			
11.4.3	Installation	46			
12.0	SDI Devices	48			
12.1	Description	48			
12.2	Installation	48			
12.3	D9131A Parallel Printer Interface Module....	48			
12.3.1	Switch Settings	48			
12.3.2	Supervision	48			
12.4	SDI Address 80.....	48			
12.4.1	Serial Interface Modules (SIMs)	48			

Figures

Figure 1:	System Configuration	8
Figure 2:	Enclosure Mounting.....	14
Figure 3:	Ground Fault Detection.....	15
Figure 4:	Reset Pin.....	16
Figure 5:	Non-Power-Limited Wiring	20
Figure 6:	Charging and Battery LEDs.....	21
Figure 7:	RJ31X Wiring	26
Figure 8:	Phone Connector, Phone LED, and Operation Monitor LED Locations.....	26
Figure 9:	On-board Point Sensor Loop Wiring.....	28
Figure 10:	Wiring for Installation Using the Ademco AB-12 Bell/Housing	30
Figure 11:	Connecting the D8125 POPEX to the D7212GV2 Panel	33
Figure 12:	Program Record Sheet.....	36
Figure 13:	D8128D OctoPOPIT Layout.....	37
Figure 14:	Connecting D8128D OctoPOPITs to the D7212GV2.....	39
Figure 15:	Wiring Multiple D8128Ds Using Molex [®] Connectors	40
Figure 16:	D8128D OctoPOPIT Sensor Loops.....	41
Figure 17:	D8129 Connections to the D7212GV2 ..	42
Figure 18:	Power at Keypads.....	45
Figure 19:	Keyswitch Wiring.....	46
Figure 20:	D9133 Jumper Settings.....	49
Figure 21:	DX4020i DIP Switch Settings.....	49
Figure 22:	DX4020 DIP Switch Settings.....	50
Figure 23:	D9133TTL-E Jumper Settings	50
Figure 24:	Reset Pin.....	51
Figure 25:	D7212GV2 Faceplate	52
Figure 26:	D7212GV2, Power Supply Side	53
Figure 27:	D7212GV2, Input Points and Peripheral Devices	54
Figure 28:	D7212GV2, SDI Devices	55

Tables

Table 1:	Related Documentation.....	6
Table 2:	Control Panel Capabilities	8
Table 3:	Compatible Accessories	10
Table 4:	Compatible Keypads	12
Table 5:	Ground Fault Detection Status	16
Table 6:	Ground Fault Impedance Specifications	16
Table 7:	Battery Discharge and Recharge Schedule	22
Table 8:	Charging Status and Low Battery LEDs.....	23
Table 9:	Point Parameters	28
Table 10:	POPEX Modules.....	31
Table 11:	Extra Point Events	31
Table 12:	Off-Board Point Errors	32
Table 13:	Data Expansion Loop Wire Specifications	34
Table 14:	D8128D OctoPOPIT Switch Settings.....	37
Table 15:	Switch 5 Settings for Line Termination..	37
Table 16:	Terminal Strip Connections.....	38
Table 17:	D8129 OctoRelay Switch Settings	42
Table 18:	Keypad Address Settings.....	44
Table 19:	Keypad Connections	44
Table 20:	SDI Device Connections.....	48
Table 21:	Printer Address Switch Settings.....	48
Table 22:	Zonex 1, Points 9 to 40	56
Table 23:	Specifications	58

1.0 Introduction

This manual addresses the operation and installation of the D7212GV2 Control Panel only and should not be used with the D9412GV2, D7412GV2, D9412G, D7412G, D7212G, D9412, D9112, D9112B1, D7412, D7212, or D7212B1 control panels.

Throughout this guide, the words “control panel” refer to the D7212GV2 Control Panel. *Table 2* on page 8 provides an overview of the capabilities of the D7212GV2.

Table 1: Related Documentation	
Name of Documentation*	Part Number
<i>D1255 Installation Instructions</i>	74-06819-000
<i>D1256/D1257 Installation Instructions</i>	74-06925-000
<i>D1260 Installation Guide</i>	48101
<i>D1260 Owner's Manual</i>	50410
<i>D5200 Operation Manual</i>	74-06176-000
<i>D720 Installation Instructions</i>	74-06918-000
<i>D7212GV2 Release Notes</i>	43856
<i>D8125MUX Operation & Installation Guide</i>	36796
<i>D9210B Operation and Installation Guide</i>	32206
<i>D7212GV2 Release Notes</i>	F01U003xxx
<i>D7212V2G Approved Applications Compliance Guide</i>	F01U003806
<i>D9412GV2/D7412GV2/D7212GV2 Installation and Troubleshooting Quick Reference Guide</i>	F01U003638
<i>D7212GV2 New Features</i>	43746
<i>D7212GV2 Operation and Installation Guide (this document)</i>	F01U003641
<i>D7212G Program Entry Guide</i>	F01U003804
<i>D7212V2G Program Record Sheet</i>	F01U003803
<i>RPS Operations Manual</i>	38849
<i>Security System Owner's Manual</i>	71-06633-000
<i>Security System Owner's Manual Supplement</i>	33267
<i>UL Certified Bank Safe and Vault Applications Technogram</i>	73-07302-000
<i>9000/G/GV2 Series Technical Service Note: UL Smoke Detector Compatibility</i>	33284
<i>D8128D Installation Guide</i>	41323
<i>D268/D269 Operation and Installation Instructions</i>	74-004758-000
<i>D279A Operation and Installation Instructions</i>	46458
* To obtain any of these documents, please contact Bosch Security Systems Technical Support and request the documentation by its corresponding part number.	

2.0 Lightning Strikes

The control panel is designed to significantly reduce electromagnetic interference and malfunction generally caused by lightning.

2.1 Effects

Any electronic system can be struck directly by lightning or be adversely affected by a lightning strike near the system. When lightning strikes, several things happen:

- An electromagnetic wave spreads from the point of the strike inducing high voltages in nearby conductors.
- The voltage changes substantially on electrical grounds near the lightning strike.
- High voltages are induced upon anything directly struck by lightning.

Symptoms of installations that lightning might strike or affect are Missing Trouble, Missing Alarm, or Point Bus Trouble events. Occasionally, Reboot and Watchdog events might be sent because the control panel tried to reset itself.

Electronic systems, including control panels, cannot be completely immune to direct or indirect lightning strikes; however, some proven installation practices might greatly reduce the risk of undesirable effects.

2.2 Precautions during Installation

To minimize the risk of undesirable effects from lightning strikes on high risk installations that use a point-bus technology:

- Do not run wiring outside the building.
- If you must install the unit in a metal building, keep the wiring at least 2 ft away from external metal surfaces.
- Earth ground the unit correctly. Do not use an electrical ground or telephone ground.
- Avoid running wires near telephone, data, or power lines inside a building. Historical evidence shows that locating control panel wiring at least 2 ft away from telephone, data, or power lines is successful at minimizing lightning damage. When your data lines must cross the path of AC or other wiring, cross the lines perpendicularly.

3.0 Overview

3.1 Configuration and Parts

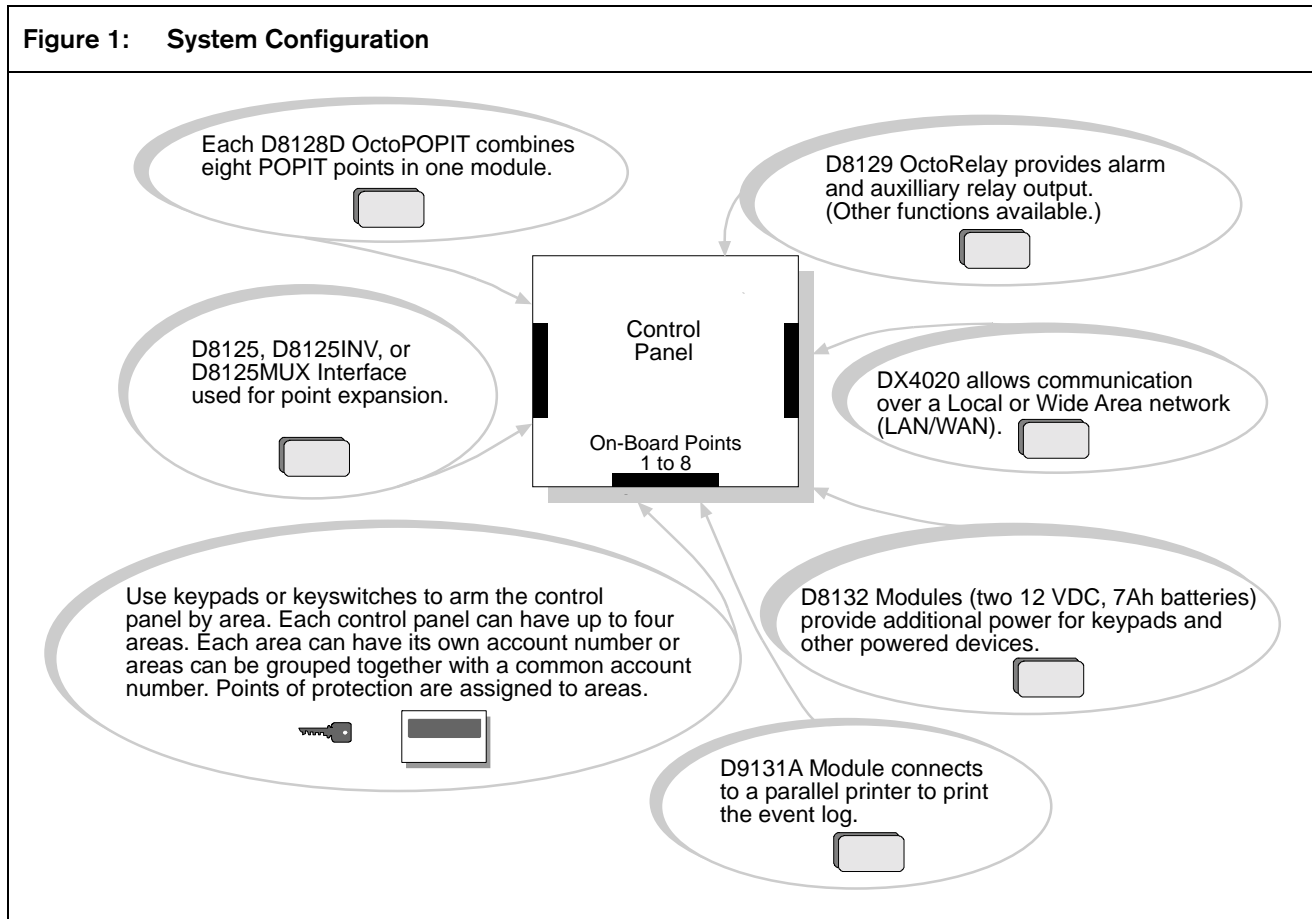

Table 2: Control Panel Capabilities

Features	D7212GV2
Access Control	No
Arm/Disarm Passcodes	99
Cards/Tokens	N/A
Passcode-Protected Custom Functions	4
Number of Printers	1
Number of Points	40
Number of Relays	24
Number of Areas	4

3.1.1 Parts List

The D7212GV2 Control Panel is shipped pre-assembled from the factory with the following parts:

Literature Pack

- *D9412GV2/D7412GV2/D7212GV2 Installation and Troubleshooting Quick Reference Guide* (P/N: F01U003805)
- *D7212GV2 Program Record Sheet* (P/N: F01U003803)
- *9000/G/GV2 Series Technical Service Note: UL Smoke Detector Compatibility* (P/N: 33284)
- *7000/9000 Series Point Chart Label* (P/N: 79-06660-000)

Assembly

- PC board
- Faceplate shield
- Mounting skirt
- One #6 x 1/4-in. screw

3.1.2 Parts Available by Separate Order

Order the following components separately to complete a basic 8-point installation.

- D1255, D1256, D1257, D1260, or D720 Command Center (or keypad)
- D1640 Transformer
- D126 or D1218 Battery
- D161 or D162 Phone Cord (order two cords if using the D928 Dual Phone Switcher)
- D8103, D8108A, or D8109 Enclosure

Configured packages are also available. Please consult the *Bosch Security Systems Product Catalog*.

The following literature is available in a separate literature package for dealers.

- *D7212GV2 Operation and Installation Guide* (P/N: F01U003805)
- *D7212GV2 Approved Applications Compliance Guide* (P/N: F01U003806)
- *D7212GV2 Program Entry Guide* (P/N: F01U003804)
- *D7212GV2 Program Record Sheet* (P/N: F01U003803)

3.2 Accessories

Refer to the Bosch Security Systems product catalog for additional information.

Table 3: Compatible Accessories			
Model	Title	Model	Title
D122/D122L	Dual Battery Harness	D1256	Fire Command Center
D125B	Powered Loop Interface Module	D1257	Fire Annunciator
D127	Reversing Relay	D1260	Alpha V Command Center
D129	Dual Class A Initiation Circuit Module	D1640	16.5 VAC 40 VA Transformer
D130	Relay Module	D5200	Programmer
D136	Plug-In Relay	D5500	Remote Programming Software (RPS)
D161	Phone Cord [2.4 m (8 ft)]	D8004	Transformer Enclosure
D162	Phone Cord [0.6 m (2 ft)]	D8121A, D8122	Derived Channel STU
D185	Reverse Polarity Module	D8125	POPEX Module
D192C/D192G	Bell Circuit Supervision Module	D8125MUX	Multiplex Bus Interface
		D8125INV*	Wireless Interface Module
D279A	Independent Zone Control (On-Board and OctoPOPIT Points)	D8128D	OctoPOPIT Module
D442	Bells [4 cm (10 in.)]	D8129	OctoRelay Module
D448/D449	Mini-horns	D8130	Release Module
D720	Command Center (Area LED)	D9127U/T	POPIT Module
D720R	LED Command Center (red)	D9131A	Parallel Printer Interface Module
D720W	LED Command Center (white)	ZX776Z	PIR Motion Sensor [15 m (50 ft)] with POPIT
D1218	12 V, 17.2 Ah Rechargeable Battery	ZX794Z	PIR Motion Sensor [24 m (80 ft)] with POPIT
D1255	Command Center (General Purpose)	ZX865	PIR/Microwave Motion Sensor [+1.7°C (+35°F)] with POPIT
D1255R	Text Command Center (red)	ZX938Z	PIR Motion Sensor [18 m (60 ft.)] with POPIT
D1255W	Text Command Center (white)	ZX970	PIR/Microwave Motion Sensor [+1.7°C (+35°F)] with POPIT

* The D8125INV was not investigated by UL. Do not use D8125INV in UL Listed installations.

3.3 Features in the D7212GV2

3.3.1 SDI Molex Connector

Use the SDI Molex Connector to connect easily an SDI device with the SDI bus, without needing to disconnect wires connected to the SDI terminals.

Possible applications include:

- Connecting a DX4010i to program the control panel with Remote Programming Software (RPS) at the premises
- Connecting a keypad to test the control panel.



For a D1260ATM keypad, set the address of the DIP switch to 7. The default for Address 7 has the Area Scope and Enhanced CMD Ctr parameters set to **Yes**.



Do not connect the D5200 Programmer to the SDI Molex connector.

3.3.2 Tip and Ring Posts

The tip and ring posts allow connecting a phone or buttset for the purpose of troubleshooting communications between the control panel and the central station. With this connection, the dial tone, ACK tone handshake, and ACK and NACK signals can be monitored.

3.3.3 Super Capacitor

The D7212GV2 has a capacitor called Super Cap. This component preserves the parameters stored in the control panel's RAM chip when the lithium battery is replaced. The Super Cap can retain voltage for up to 30 minutes after the lithium battery is removed.

Plan to replace the lithium battery after 3 to 5 years of continual service.



When replacing the lithium battery, ensure that you disconnect the primary AC power and secondary battery power from the control panel **before** you remove the old battery. Then install the new battery and connect the primary AC and secondary battery power to the control panel.

3.3.4 Telephone Line Sniff

The D7212GV2 monitors the phone line for the programmed supervision interval before indicating a phone line trouble. Phone line trouble occurs when the phone line voltage drops to 6 V or below, without a corresponding 8 mA to 13 mA increase in current.

3.3.5 Points

The Bosch Security Systems D7212GV2 Control Panel provides up to 40 points of protection. Point programming parameters determine the control panel's response to open and shorted conditions on the sensor loop for the point. Several options allow individual point programming to custom-fit the protection to the installation.

Points 1 to 8 are located on the circuit board (on-board points). They are standard sensor loops. The remaining off-board points are POPIT points using D8128D OctoPOPITs, D8125 POPEX Modules and D9127 or D8127 POPITs. MUX devices can also be used with D8125MUX or wireless transmitters with the D8125INV.

3.3.6 Areas and Accounts

The system supports up to four separate areas. You can assign all points to a single area or distribute them over as many as four areas.

The control panel is armed and disarmed by area, and several areas can be armed and disarmed with one menu function. A passcode can also be assigned an authority level that allows a user to arm an area from a remote keypad in another area. Assigning each area its own account number creates four separate accounts in one control panel. Assigning the same account number to different areas groups them together in a single account.

Area options include exit tone and delay, separate fire and burglary outputs, and multiple opening and closing windows. Area type can be used to create area interdependencies for arming purposes.

3.3.7 Digital Communicator

The control panel uses a built-in digital communicator to send reports to the receiver. The control panel sends reports in either the Modem IIIa² or BFSK format. The MPU and line cards for the D6500 receiver must have software revision 8.00 (or greater) installed to accept Modem IIIa² reports from the control panel. Refer to the D6500 or D6600 literature to determine the MPU software version.

The control panel connects to an RJ31X or RJ38X jack for telephone line seizure. Connecting to the RJ31X complies with FCC regulations for using the public telephone network. The control panel can be programmed to direct reports to four separate telephone numbers.

The system can route groups of Event Reports to four different destinations. Each report group can be programmed to send reports to one or more destinations. Primary and backup reporting paths can be programmed for each destination and each report group. A custom option allows specification of individual Event Reports to be sent.

3.3.8 Keypads

Up to 32 unsupervised keypads can be connected to the system. The available power, number of supervised keypads, and number of areas covered affect the total number of keypads that can be connected.

The system can supervise up to eight keypads. The control panel sends a Serial Device Trouble Report, SDI FAILURE in the Modem IIIa² format or TROUBLE ZN D in the BFSK format, if it loses communication with a supervised keypad.

More than eight keypads can be added, but supervision of only eight is possible. *Table 4* shows the compatible keypads with the D7212GV2 Control Panel. Refer to *Keypad* in the *D7212GV2 Program Entry Guide* (P/N: F01U003804) for complete details on programming keypad options.

Table 4: Compatible Keypads		
Model	Display	Application
D1255	16-character alphanumeric	Fire/Burglary/Access
D1256	16-character alphanumeric	Fire
D1257	16-character alphanumeric	Fire
D1260	4-line by 20-character	Fire/Burglary
D720	8 LED	Fire/Burglary

3.3.9 Keyswitch

Maintained or momentary closure devices such as keyswitches allow any of the four available areas to be armed or disarmed. Point programming determines the loop responses and which area a keyswitch controls.

3.3.10 Event Memory

The system uses event memory to store events for each area. A D1255 Keypad or D1260 Keypad assigned to an area allows viewing of the events for the area. The control panel clears the events for an area from event memory and starts storing new events when the area is master armed.

3.3.11 Event Log

The system stores 500 to 1000 events and event modifiers from all areas in its event log. Event modifiers add information about an event to the log. Some events are always followed by a modifier. For example, the system adds at least two items to the log each time an area is armed or disarmed, the open (or close) event and an event modifier showing the previous arming state.

All events and their modifiers can be stored even if the control panel does not send a report for them. The log can be viewed at a keypad, printed locally using the D9131A Parallel Printer Interface Module and a parallel printer, or uploaded using Remote Programming Software (RPS).

For a list of the log events and event modifiers, refer to the appendix in the user's guide for the keypad.

3.3.12 Ground Fault Detection

The Earth Ground Terminal on the control panels is electrically isolated from all other terminals to allow the D7212GV2 to detect ground fault conditions. A Ground Fault Detect Enable switch (S4) is located just under Terminal 10, Earth Ground, on the control panel. Refer to *Section 4.5.2 Ground Fault Detect Enable* on page 15 for information on operating this function.

3.3.13 Ground Fault Detection Added Feature

When Ground Fault Detect is enabled (S4 closed), Points 1 to 8 can be used for non-powered fire-initiating devices such as heat detectors, four-wire smoke detectors, and pull stations. A D125B Powered Loop Interface or a D129 Dual Class A Interface Module is not required when connecting the non-powered fire-initiating devices to Points 1 to 8.

3.3.14 Programming

Use the Bosch Security Systems D5200 Programmer or the Remote Programming Software (RPS) to program the D7212GV2 Control Panel. Refer to the *D7212GV2 Program Entry Guide* (P/N: F01U003804) for programming options.

3.3.15 Other Features

The D7212GV2 Control Panel has many programmable features. Some of the features are listed below. Complete details on all features are in the *D7212GV2 Program Entry Guide* (P/N: F01U003804).

- Supervision of AC (primary power), battery (secondary power), Zonex and SDI buses, central processing unit (CPU), a maximum of three printers, and two telephone lines
- Automatic System Test Reports
- Remote access for programming, diagnostics, and log uploads using the remote programming software (RPS)
- Fire alarm verification
- Programmable alarm output
- Programmable relay output using the D8129 OctoRelay Module
- Opening and closing windows
- Skeds (scheduled events)

4.0 Installation

4.1 Installation Preparation

This section contains a general installation procedure and refers to other sections of the document for detailed instructions.

Review this document and the *D7212GV2 Program Entry Guide* (P/N: F01U003804) before beginning the installation to determine the hardware and wiring requirements for the features used.

Have the following documentation available when reading through this guide:

- *D7212GV2 Program Record Sheet* (P/N: F01U003803)
- *Security System Owner's Manual* (P/N: 71-06633-000) and *Security System Owner's Manual Supplement* (P/N: 33267)
- Command center (keypad) installation manual (D1255, D1256, D1257, D1260, or D720)

Before installation, become familiar with the operation of the D5200 Programmer or the RPS.

4.2 Enclosure Options

Mount the control panel assembly in any of the Bosch Security Systems enclosures listed:

- D8103 Universal Enclosure (tan)
- D8108A Attack Resistant Enclosure (tan)

Refer to the *D7212GV2 Approved Applications Compliance Guide* (P/N: F01U003806) to determine if the application requires a specific enclosure.

4.3 Mounting Enclosure

1. Run the necessary wiring throughout the premises.
2. Mount the enclosure in the desired location. Use all five enclosure mounting holes. Refer to *Figure 2*.
3. Pull the wires into the enclosure.

Electro-Magnetic Interference (EMI) can cause problems on long wire runs. Refer to *EMI on Long Wire Runs* in the *D9412GV2/D7412GV2/D7212GV2 Installation and Troubleshooting Quick Reference Guide* (P/N: F01U003638).

Figure 2: Enclosure Mounting

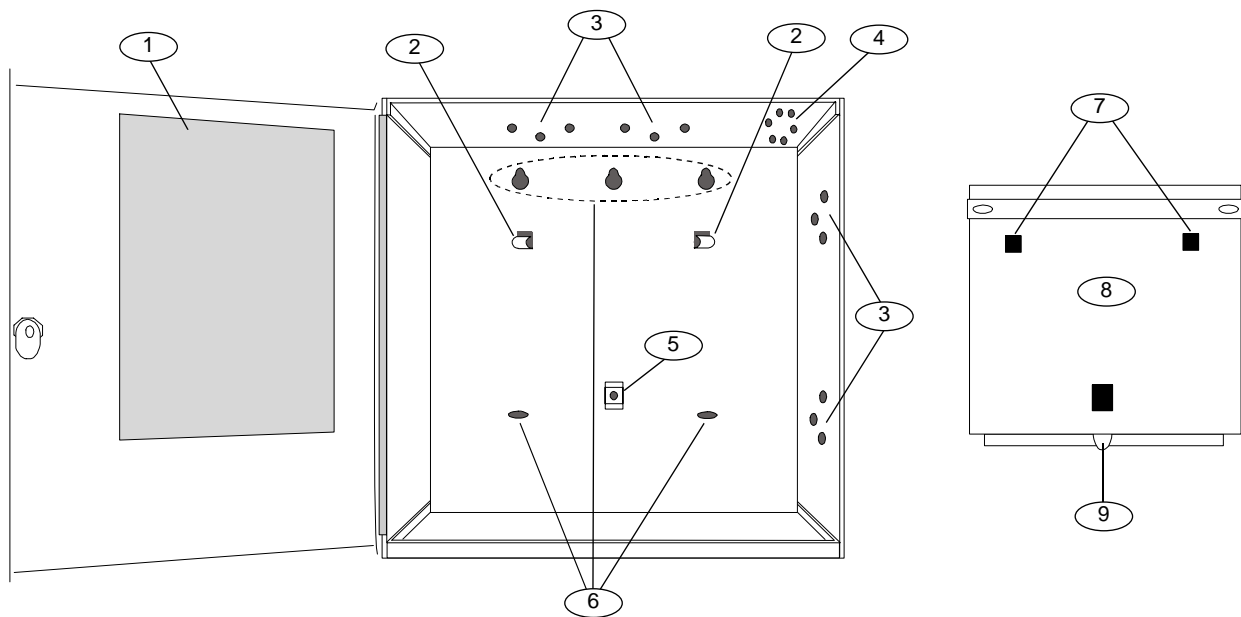

1 - Point chart label

2 - Mounting skirt hooks (2)

3 - Module mounting holes (12)

4 - Tamper switch mounting holes (5)

5 - Skirt mounting hole (1)

6 - Enclosure mounting holes (5)

7 - Mounting skirt hook holes (2)

8 - Back of D7212GV2 Control Panel

9 - Lock down tab

4.4 Installing the Control Panel

1. Place the control panel over the inside back of the enclosure, aligning the large rectangular openings of the mounting skirt with the mounting hooks of the enclosure. Slide the control panel down so it hangs on the hooks. Refer to *Figure 2* on page 14.
2. Remove the tape from the #6 x 1/4-in. screw in the mounting tab on the control panel. The screw passes through the mounting tab and into the skirt mounting hole in the enclosure. Tighten the screw to secure the control panel in the enclosure.
3. Connect earth ground to the control panel before making any other connections. Refer to *Section 4.5 Connecting Earth Ground*.

4.5 Connecting Earth Ground

4.5.1 Terminal 10

To help prevent damage from electrostatic charges or other transient electrical surges, connect the system to earth ground at Terminal 10 before making other connections. Recommended earth ground references are a grounding rod or a cold water pipe.



Warning:

Do not use telephone or electrical ground for the earth ground connection. Use 1.8 mm (14 AWG) to 1.5 mm (16 AWG) wire when making the connection.

Do not connect other control panel terminals to earth ground.

4.5.2 Ground Fault Detect Enable

- A ground fault is a circuit impedance to earth ground. The control panel has a ground fault detection circuit that, when enabled, detects ground faults on Terminals 1 to 9 and 11 to 32. The control panel also detects and annunciates ground faults on any device connected to it.
- To enable ground fault detection, the Ground Fault Detect Enable jumper (S4) (*Figure 3*) must be locked (closed) and a non-zero value must be entered in the Area 5 Silent Alarm Relay. When jumper S4 is in the unlocked (open) position, the control panel does not detect ground fault conditions.

- If a ground fault condition occurs, the keypads display `SERV C GND FAULT` and the control panel sends a `GROUND FAULT TROUBLE, AREA 1` (Modem IIIa² format only).

When the control panel recognizes that the ground fault condition is corrected, and remains corrected for between 5 to 45 consecutive seconds, a Restoral Report is sent.



The D7212GV2 Control Panel logs and prints a Ground Fault event as a Trouble Point 256 if communicating in Modem IIIa² format. If communicating in BFSK format, the D7212GV2 generates an Alarm Zone 5 event.

Figure 3: Ground Fault Detection

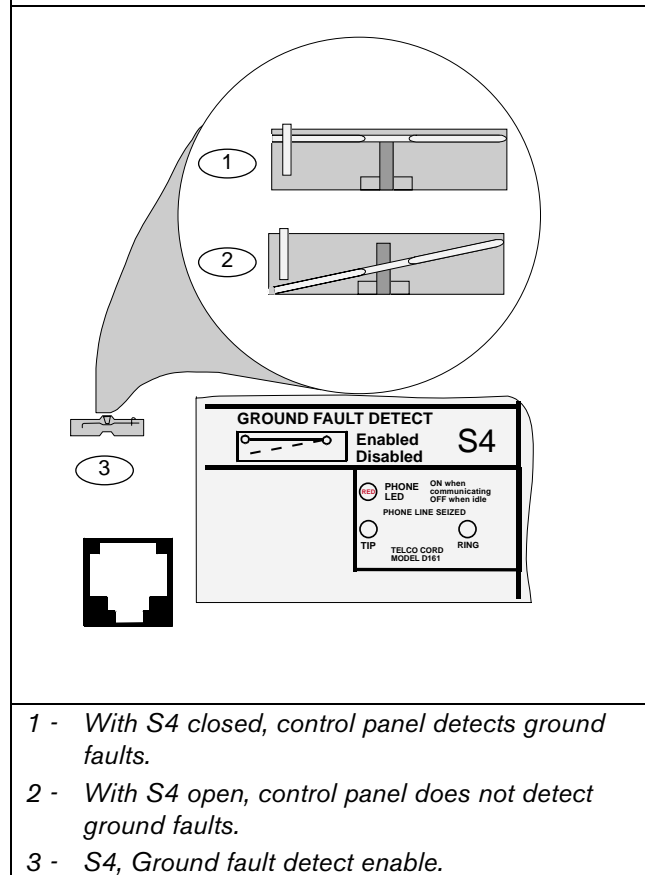

4.5.3 Enabling Ground Fault Detection

To configure the D7212GV2 Control Panel to enable ground fault detection:

1. Set the silent relay in Area 5 to any value from 1 to 128. **Do not use a zero (0) value.**



The default value for the Area 5 silent relay is 0 (zero). The 0 value disables the ground fault detection function.

2. Close Switch S4 (*Figure 3*). Refer to *Table 5* for information about the conditions for enabling and disabling the Ground Fault Detection Circuit.

Ground Fault Detection Circuit	Switch S4	Value of Area 5 Silent Relay Alarm
Enabled	Closed	1 to 128
Disabled	Closed	0
	Open	0 to 128

4.5.4 D7212GV2 Ground Fault Specifications

Table 6 provides the impedance specifications for detecting ground faults when any terminal or field wiring is shorted to ground.

Impedance	Control Panel Detects Ground Fault
$\leq 300 \Omega$	Yes
300Ω to $200 \text{ k}\Omega$	No
$\geq 200 \text{ k}\Omega$	Detection depends upon the terminal

4.5.5 Locking the Reset Pin

Locking the reset pin disables the control panel (*Figure 4*). When the control panel is disabled, the system ignores the keypads and points. **CALL FOR SERVICE** appears in keypad displays when the pin is locked down.

On-board relays (Terminals 6 and 7) and off-board relays deactivate when the control panel is reset. Terminal 8 has power when the relay is deactivated. Activation interrupts power at that terminal. The on-board relay (Terminal 8) remains deactivated when the reset pin is locked in the disable position.

Releasing the reset pin from the closed position resets the control panel. The control panel resets all its timers, counters, indexes, and buffers. Any points that restore after a reset do not generate Restoral Reports.

If the reset pin is placed in the disable position when all areas are armed, there must be an entry in the Answer Armed program item. Refer to *RPS Parameters* in the *D7212GV2 Program Entry Guide* (P/N: F01U003804).

Locking the pin in the disable position applies power to the control panel and charges the battery while the detection devices and keypads are installed.

Figure 4: Reset Pin

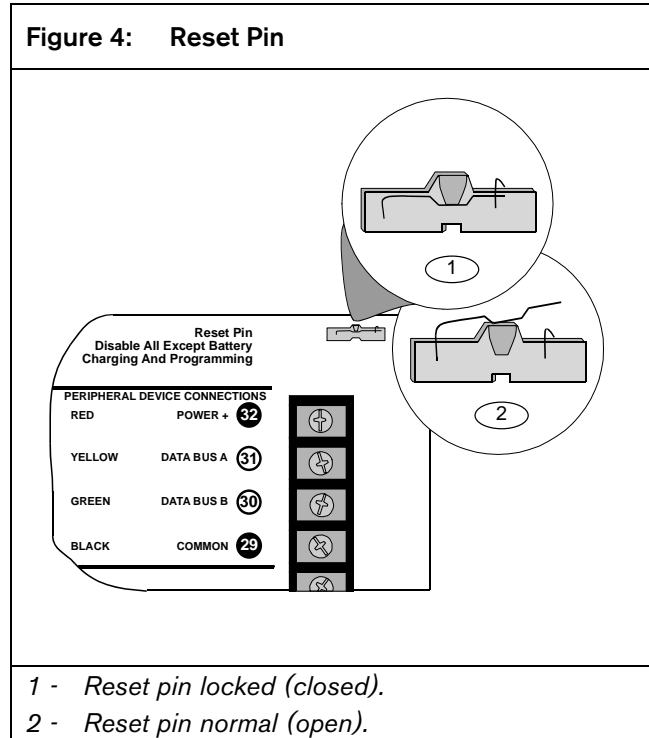

4.6 Completing the Installation

If not already complete, make the earth ground connection to Terminal 10 and lock the reset pin in the closed position.

4.6.1 Charging the Battery

Connect the battery, then the transformer to allow the control panel to charge the battery while you complete the installation. Refer to *Section 5.0 Power Supply* on page 19 for instructions.

On-board Buzzer Sounds at Power Up and Reset:

The system performs a series of self-diagnostic tests of hardware, software, and programming at power up and at reset. The buzzer on the control panel sounds during the tests. The self-diagnostics tests complete in approximately 1 to 3 seconds.

If the control panel fails any test, the buzzer continues sounding and a System Trouble message appears at the keypads. Refer to *Problems Found during Self-Diagnostics* in the *D9412GV2/D7412GV2/D7212GV2 Installation and Troubleshooting Quick Reference Guide* (P/N: F01U003638) for a description of each system trouble message.

Touch Terminal 10 First: If the on-board buzzer sounds briefly when the control panel is touched, any static charge you carry discharges to the control panel.



Avoid electrostatic discharge. Always touch Terminal 10, the earth ground connection, before beginning work on the control panel.

If the control panel receives an electrostatic discharge, it might generate Watchdog Reset and Param Fail events. Refer to *Watchdog Reset Reports* in the *D9412GV2/7412G/D7212GV2 Installation and Troubleshooting Quick Reference Guide* (P/N: F01U003638) for a description of these events.

4.6.2 Installing and Wiring Detection Devices

Install and wire detection devices and keypads at their locations throughout the premises. **Do not** connect the control panel yet.

Section 8.0 On-Board Points on page 28 contains instructions for wiring the on-board points to detection devices. *Section 11.0 Arming Devices* on page 44 contains instructions for wiring the keypads.

Instructions for wiring the off-board point POPIT sensor loops are found in the instructions packaged with the POPIT modules.

4.6.3 Installing Modules and Relays

1. Power down the unit by unplugging the transformer and disconnecting the battery.



Always power down the unit when installing modules or relays, or when making wiring connections to the control panel.

2. Install and wire any modules required for the installation as described in the module's installation instructions.

Instructions for the D8125 POPEX Module, D8128D OctoPOPIT Module, D8129 OctoRelay Module, and D811 Arm Status Relay Module appear in this guide.

Refer to *Section 9.0 Off-Board Points* on page for D8125 and D8128D instructions. Refer to *Section 10.0 Off-Board Relays* on page 42 for D8129 and D811 instructions.

3. If using the power outputs at Terminals 7 or 8, install a D136 relay in the appropriate sockets. Refer to *Section 6.4 Programmable Power Output Terminals* 6, 7, and 8 on page 24 for instructions.

4.6.4 Connecting the On-board Points and Keypads

Connect the on-board points and keypad wiring to the system. Refer to *Section 8.0 On-Board Points* on page 28 and *Section 11.0 Arming Devices* on page 44 for instructions.

4.6.5 Powering Up

Reconnect the battery, then plug in the transformer. The buzzer sounds for two seconds when the control panel is powered up. Leave the reset pin in the locked position.

Yellow Charging Status LED Remains Lit: If the yellow charging status LED remains lit after five minutes of powering up the control panel, either the battery is deeply discharged, or too many powered devices were connected to the control panel. Combined continuous current draw for Terminals 3, 9, and 32, and the accessory connector cannot exceed 1.4 A. Refer to *Section 6.0 Power Outputs* on page 24 for help.

4.7 Programming the Control Panel

If the control panel is not already programmed, review the *D9412GV2/D7412GV2 Program Entry Guide*. Ensure that all accessory modules for desired features are available for installation. Place the reset pin in the locked position to copy or send information to and from the control panel.

Use the D5200 Programmer or the RPS to load a custom program into the control panel.

Move the reset pin to the normal position (refer to *Figure 4* on page 16). The control panel sends Reboot and Battery Reports to the receiver if programmed for reporting.

4.8 Installing the Point Chart Label



The point chart label is required for fire systems with verifications points.

A point chart label comes in the literature pack. Install the point chart label for fire or combined fire-and-burglary systems that use verification points.

Use the *D7212GV2 Program Record Sheet* (P/N: F01U003803) to gather the necessary information for completing the point chart. Fill out the label and install it on the inside of the enclosure door (refer to *Figure 2* on page 14).



Avoid smearing the entries on the chart. Use the peel-off backing to press the label in place.

4.9 Testing the System

After installing and programming the control panel, test the system completely. Test the control panel and all devices for proper operation. Test after initially programming the control panel and after subsequent programming sessions.

Refer to the *D9412GV2/D7412GV2/D7212GV2 Installation and Troubleshooting Quick Reference Guide* (P/N: F01U003638) for complete Service Walk Test instructions.

Clear after Test: To clear the event memory and report buffer, momentarily close the reset pin. Events stored in the control panel's event log are not cleared.

5.0 Power Supply

5.1 Primary Power Terminals 1 and 2

5.1.1 Primary (AC) Power Circuit

The primary source is a 16.5 VAC, 40 VA, internally-fused transformer (Bosch Security Systems Model D1640). The control panel draws 200 mA when idle and 500 mA when in an alarm state. The total available auxiliary current is 1.4 A.

Transient suppressors and spark gaps protect the circuit from power surges. This protection relies on the ground connection at Terminal 10. Ensure that you connect Terminal 10 to a proper ground. Refer to *Section 4.5 Connecting Earth Ground* on page 15.

AC Power Failure

The system indicates an AC power failure when Terminals 1 and 2 do not have power. The AC Fail Time program item sets the number of minutes or seconds without AC power before the control panel acknowledges the failure and the number of minutes or seconds after the power returns before the control panel acknowledges restored power. Refer to the *D7212GV2 Program Entry Guide* (P/N: F01U003804) for additional information about AC Fail Time.

5.1.2 Installing the Transformer



Do not short the terminals of the transformer: Shorting the terminals opens the internal fuse, causing permanent failure. Connect the transformer to Terminals 1 and 2 of the control panel before plugging it into the power source.

- Use 1.22 mm (18 AWG) wire (minimum) to connect the transformer to the control panel. The wire length should be as short as possible. The maximum length is 15 m (50 ft.). Connect the battery and plug in the transformer.
- Route telephone and sensor loop wiring away from any AC conductors, including the transformer wire. AC wiring can induce noise and low level voltage into adjacent wiring. Route data wiring away from AC and telephone wiring.



Always connect the battery first and then plug in the transformer.

- Connect the battery. Refer to *Section 5.2.2 Installing the Battery* on page 19.

- Plug the transformer into an unswitched, 120 VAC, 60 Hz power outlet only.
- Secure the transformer to the outlet with the screw provided.

D8004 Transformer Enclosure Required for Fire

Systems: Use the D8004 Transformer Enclosure for the D1640 Transformer in fire and combined fire/burglary applications. Check with the Authority Having Jurisdiction (AHJ) about mounting transformers on specific circuits.

5.2 Secondary Power Terminals

5.2.1 Secondary (DC) Power

A 12 V, 7 Ah (up to 14 Ah) sealed lead-acid rechargeable battery (D126) supplies secondary power for auxiliary and alarm outputs, and powers the system during interruptions in primary (AC) power.



Warning - Use Lead Acid Batteries Only:

The charging circuit is calibrated for lead-acid batteries. Do not use gel-cell or nicad batteries.

Extra Batteries Increase Back-up Time: To increase battery back-up time, connect a second 12 V, 7 Ah battery in parallel to the first battery to form a 12 V, 14 Ah battery. Use a D122 Dual Battery Harness to ensure proper and safe connection.



Caution: When connecting two D1218 Batteries to the control panel, both must have the same capacity (use two 17.2 Ah batteries or two 18 Ah batteries).

D1218 Battery

The D1218 is a 12 V, 17.2 or 18 Ah battery for use in applications requiring extended battery standby time. Up to two D1218 batteries can be connected when used with a D122 Dual Battery Harness.

5.2.2 Installing the Battery

- Place the battery upright in the base of the enclosure.
- Locate the red and black leads supplied in the literature pack.
- Connect the black battery lead to Terminal 4, and then to the negative (-) side of the battery.

4. Connect the red battery lead to Terminal 5, and then to the positive (+) side of the battery.



Warning: High current arcs are possible. The positive (red) battery lead and Terminal 5 can create high current arcs if shorted to other terminals or the enclosure. Use caution when working with the positive lead and Terminal 5. Always disconnect the positive (red) lead from the battery before removing it from Terminal 5.



Caution: The battery terminals and wire are **not** power limited. A 6.4 mm (0.250 in.) space must be maintained between the battery terminals, battery wiring, and all other wiring. Battery wiring cannot share the same conduit, conduit fittings, or conduit knock-outs with other wiring. Refer to *Figure 5*.

Figure 5: Non-Power-Limited Wiring

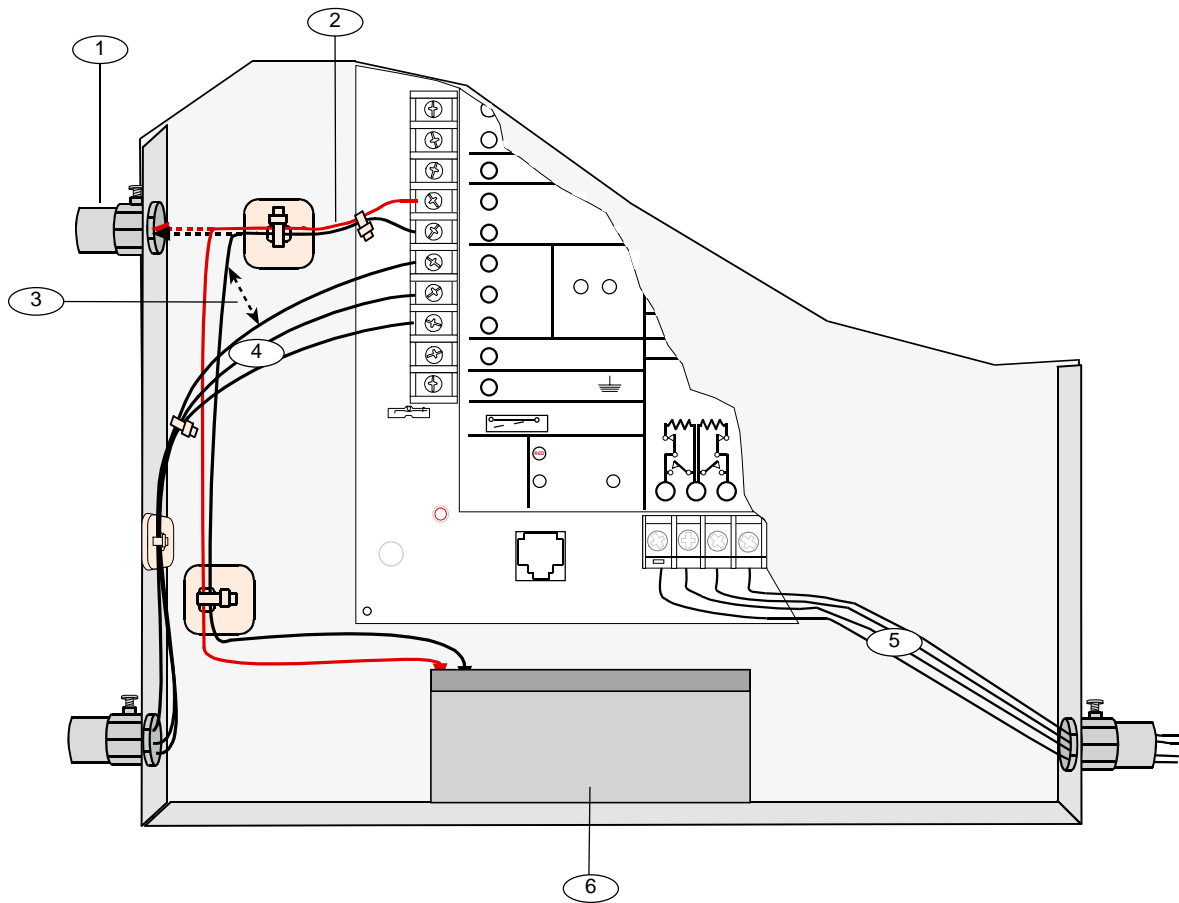

1 - Conduit, required only if external batteries are used.

2 - Battery wires

3 - 6.4 mm (0.25 in.) minimum spacing.
To ensure proper spacing, use tie-wraps or similar devices to secure wires.

4- Option wires

5- Output or zone wires

6- Standby battery

5.2.3 Replacing the Battery

Replace batteries every 3 to 5 years under normal use. Record the date of installation directly on the battery.



Caution: Exceeding the maximum output ratings or installing the transformer in an outlet that is routinely switched off causes heavy discharges. Routine heavy discharges can lead to premature battery failure.

D8132 Boost Battery Backup: Adding a D8132 Battery Charger Module supports additional batteries of up to 27 Ah capacity, if required.

The D8132 Battery Charger Module can be used to connect two additional batteries for a total of four.

The control panel plus any connected D8132 Modules and auxiliary power supplies must be on the same AC circuit to discharge evenly if AC power fails. The number of D8132 Modules is determined by the number of available outlets on the same circuit. Refer to the Standby Battery and Current Rating Chart in the *D9412GV2/D7412GV2 Approved Applications Compliance Guide* (P/N: F01U003806) for battery standby time calculations.



In applications where the supervision of two batteries is required by the AHJ, use a D113 Battery Supervision Module.

5.2.4 Battery Supervision

When battery voltage drops to 13.8 VDC, the yellow Charging Status LED lights. When the battery voltage drops to 12 VDC to 11.8 VDC, the red Low Battery LED lights, and the keypad or keypads display `SERVCLOW BATT`. The control panel (if programmed for power supervision) sends a `BATTERY LOW` report in the Modem IIIa² communication format. It sends a `TROUBLE ZN 9` report in the BFSK format.

If the battery is missing or shorted, the red Low Battery LED flashes at the same rate as the green Operation Monitor LED. If the control panel is programmed for power supervision, it sends a `BATTERY MISSING` report in the Modem IIIa² communication format, or `TROUBLE ZN 9` report in the BFSK format.

When battery voltage returns to 13.7 VDC, the Low Battery LED turns off and the keypad or keypads clear the `SERVCLOW BATT` message. If the control panel is programmed for power supervision, it sends a `BATTERY RESTORAL` report in the Modem IIIa² communication format or a `RESTORAL ZN 9` report in the BFSK format. At 13.9 VDC, the yellow Charging Status LED stops lighting.

Figure 6: Charging and Battery LEDs

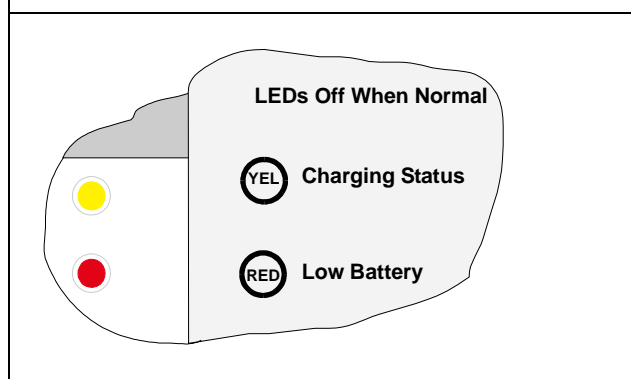

Investigate Low Battery reports immediately: If primary (AC) power is off and the discharge continues, the control panel becomes inoperative when the battery voltage drops below 10.2 VDC.

5.2.5 Battery Charging Circuit

Float Charge

The float voltage for the battery charging circuit is 13.9 VDC at a maximum current of 1.4A, less any devices connected to the control panel. If the float voltage drops below 13.8 VDC due to overload or battery discharge, the yellow charging status LED lights.

Loss of AC Load Shed Relay protects battery:

During an AC power loss, the battery supplies all power to the security system. If the battery voltage falls below 10.0 V during an AC power loss, a load shed relay isolates the battery from the control panel and disables the control panel. Load shed protects the battery from being damaged by deep discharge. When AC power restores, the load shed relay reconnects the charging circuit on the control panel to the battery and the battery begins to recharge.

Overcharge Load Shed With AC Present: If more than 1.4 A of auxiliary current draw from the control panel occurs, the battery supplies the current and begins to discharge. If this situation is not corrected, the battery continues to discharge and at 11.8 VDC to 12.0 VDC, the keypads display `Serv Low Batt`.

When the battery voltage drops below 10.0 VDC, the control panel shuts down. Remove all loads to the control panel and disconnect AC power. Add a new battery and reconnect AC power.

Reset the control panel by momentarily placing the reset pin in the disable position. Refer to *Figure 4* on page 16. The red Low Battery LED continues flashing until the control panel resets.

A shorted battery condition is created either by a shorted cell inside the battery or by a short on Terminals 4 and 5. A shorted battery might cause the control panel to operate in an unsafe way. This condition generates WATCHDOG RESET reports.

5.2.6 Battery Discharge and Recharge Schedule

Table 7: Battery Discharge and Recharge Schedule

Discharge Cycle	
AC Off:	AC Fail Report when AC fails, if control panel is programmed to report AC failure at occurrence.
13.9 VDC:	Charging float level.
13.8 VDC:	Charging status LED on.
12.0 VDC:	Low Battery and AC Fail Reports if programmed. Low battery LED on.
< 10.0 VDC:	Battery load shed (processing functions continue if AC is present).
Recharge Cycle	
AC On:	Load shed relay reset; battery charging begins; Battery Trouble and AC Restoral Reports sent.
13.7 VDC:	Battery Restoral Reports sent. Low battery LED off.
13.9 VDC:	Charging status LED off; battery float charged.

Table 8: Charging Status and Low Battery LEDs

Type	LED		Action
	Color	State	
Charging Status LED	Yellow		Shows the changing status of the battery. Refer to Figure 6 on page 21 for location.
	Yellow	Off	Battery is fully charged. If the battery is missing, shorted, or reversed, the Charging Status LED is off, but the red Low Battery LED is flashing.
	Yellow	On	Battery float charge is below 13.8 VDC. If AC is present, the battery is charging. Indicates the combined current draw from all outputs exceeds 1.4 A. This is normal under alarm conditions for non-fire systems with sirens or bells drawing more than 1.4 A. If the LED lights regularly for extended periods or does not go out, check the current draw for devices connected to the power outputs. Refer to <i>Section 6.0 Power Outputs</i> on page 24 for instructions.
	Yellow	Flash once per minute	System is checking the battery.
Low Battery LED	Red		Shows the condition of the battery. Refer to Figure 6 on page 21 for location.
	Red	Off	Battery is fully charged.
	Red	On	Battery voltage dropped to between 12.0 VDC and 11.8 VDC. LED turns off when voltage reaches 13.7 VDC.
	Red	Flash (same as green LED)	Green LED is Operation Monitor LED. Battery is missing or shorted.

6.0 Power Outputs

6.1 Circuit Protection

Three Positive Temperature Coefficients (PTCs) protect the control panel from short circuits on the continuous and programmable power outputs. If the control panel is programmed for power supervision and a short circuit occurs on one of the power outputs, the control panel sends a BATTERY LOW or BATTERY MISSING for Bosch Security Systems Modem IIIa² Communication Format, or TROUBLE ZN 9 for BFSK. One PTC protects :

- Terminal 3: Auxiliary Power
- Terminal 32: Zonex Power.



A short-circuit on one terminal disrupts power to the other terminals.

Another PTC protects:

- Terminal 6: Alarm Power Output
- Terminal 7: Alternate Alarm Power Output
- Terminal 8: Switched Auxiliary Power.

The third PTC protects Terminal 32: Power +.

6.2 Total Available Power

The system produces up to 1.4 A of combined power at 10.2 VDC to 13.9 VDC for all powered devices. The outputs listed below share the available power. These outputs are shown as red circles on the faceplate.

Terminal 3 - Auxiliary Power: Use this terminal to power devices requiring continuous power.

Terminal 6 (Relay A) - Alarm Power Output: Normally open, power on alarm.

Terminal 7 (Relay B) - Alternate Alarm Power Output: Normally open, power on alarm.

Terminal 8 (Relay C) - Switched Auxiliary Power: Normally closed, switches power off when the Sensor Reset command is executed.

Terminal 24 - Zonex Power: Use this terminal to power Zonex modules such as the D8125, D8128D, and D8129 Modules.

Terminal 32 - Power +: Use this terminal to power serial device interface (SDI) devices such as keypads, the D9131A Parallel Printer Interface Module, and the D9210B Wiegand Control Interface Module.

Accessory Connector: The D928 Dual Phone Line Switcher connects to the accessory connector.

6.3 Continuous Power Output Terminals 3, 8, and 32

The continuous current draw for powered devices connected to Terminals 3, 8, and 32, and the accessory connector must not exceed 1.4 A. Devices powered from these outputs must operate over a range of 10.2 VDC to 13.9 VDC.

Power Restricted for Fire and Combined Fire and Burglary Systems: Use the Fire System Power Formula to calculate the current available for fire and combined fire and burglary systems (refer to *Section 6.4 Programmable Power Output Terminals* 6, 7, and 8 on page 24).

6.4 Programmable Power Output Terminals 6, 7, and 8

6.4.1 Programming

The power outputs at Terminals 6, 7, and 8 are programmed as Relays A, B, and C. All relays are programmed in the Relays section.

Relays are assigned a relay type, (Fire Bell, for example) when they are assigned to an area. Relays can be assigned to one or more areas.

The Bosch Security Systems defaults set Relay A (Terminal 6) as a Steady Alarm Bell output, Relay B (Terminal 7) as a Pulsed Fire Bell output, and Relay C (Terminal 8) as a Verification or Reset output for smoke detectors. The *D7212GV2 Program Entry Guide* (P/N: F01U003804) contains complete instructions for programming relays. Refer to *Sections 6.4.2 Terminals 6 and 7*, *6.4.3 Fire System Power Formula*, and *6.4.4 Terminal 8* on page 25 for descriptions of the functions of each terminal.

Refer to the Bell Parameters section of the program to set the Fire Bell, Alarm Bell output responses for relays. Four annunciation patterns are available: Steady, Pulsed, California Standard, and Temporal Code 3.

Voltage Output at Terminals 6, 7, and 8

If Terminals 6, 7, and 8 do not provide the expected output, check:

- Programming for Relays A, B, and C in the relays section of the program.
- Bell Parameters section of the program to confirm that the Alarm and Fire Bell responses are programmed for the expected duration and pattern.
- Point Assignments section to confirm that each point is programmed for the expected local response.

6.4.2 Terminals 6 and 7

When activated, Terminals 6 (Relay A) and 7 (Relay B), provide positive (+) 10.2 VDC to 13.9 VDC power output. Use the power at Terminals 6 and 7 to power bells, siren drivers, piezoelectric fire sounders, electronic horns, or other devices.

Programming determines the format of the output and the conditions that activate it. One PTC protects Terminals 6, 7, and 8 against shorts.

Available Power

The system combines the 1.4 A of primary power produced by the power supply with the secondary power source (the battery) to produce a total of 2.0 A of alarm power at 10.2 VDC to 13.9 VDC. Terminals 6 and 7 share the available alarm power.

Power Restricted for Fire and Combined Fire and Burglary Systems: Fire systems are prohibited from using the battery for determining alarm power. Use the fire system power formula that follows to calculate the current available for fire and combined fire and burglary systems.

6.4.3 Fire System Power Formula

To calculate the current available at Terminals 6 and 7 for fire and combined fire and burglary systems:

1. Add together the current draws for all devices connected to Terminals 3, 8, 24, and 32, and the accessory connector. This is the total current required for the normal standby condition (NSC).
2. The current available for NSC is 1.4 A. Subtract the NSC current required calculated in *Step 1* from the NSC current available, 1.4 A. The difference is the alarm current available for Terminals 6 and 7.

In formula format:

$$1.4 \text{ A} - \text{NSC current required (Step 1)} = \text{Alarm current available}$$

Refer to the *D7212GV2 Approved Applications Compliance Guide* (P/N: F01U003806) for module or accessory current requirements.

6.4.4 Terminal 8

Terminal 8 provides continuous positive (+) 10.2 VDC to 13.9 VDC power. Relay C interrupts the power at Terminal 8 when activated. Use Terminal 8 to power smoke detectors or other devices that are reset by interrupting power. One self-resetting circuit breaker protects Terminals 6, 7, and 8 against shorts.

Verification/Reset Relay

The default program sets Relay C (Terminal 8) as a verification and reset relay. Refer to *Relay Parameters* and *Point Assignments* in the *D7212GV2 Program Entry Guide* (P/N: F01U003804) for instructions on programming verification/reset relays and points.

Performing a sensor reset at a keypad produces a five-second relay activation of verification/reset relays. The control panel ignores verification and reset points during the five seconds.

7.0 Telephone Connections

7.1 Registration

The Bosch Security Systems D7212GV2 Control Panel is registered with the Federal Communication Commission (FCC) under Part 68, for connection to the public telephone system using an RJ31X or RJ38X jack installed by the local telephone company.



An RJ31X jack can be modified by placing a jumper wire between Terminals 2 and 7 to become an RJ38X jack.

7.2 Notification

Do not connect registered equipment to party lines or coin-operated telephones. Notify the local telephone company and provide the following information before connecting the control panel to the telephone network:

- The particular line to which the control panel will be connected
- Make (Bosch Security Systems), model (D7212GV2), and serial number of the control panel
- FCC registration number: AJ9MUL-46532-AL-E
- Ringer equivalence for the control panel: 0.4B

7.3 Location

To prevent jamming of signals, wire the RJ31X or RJ38X jack before the in-house telephone system to support line seizure (*Figure 7*). Install the jack on the street side of the telephone switch, wired ahead of any PBX equipment. Line seizure temporarily interrupts normal telephone usage while the control panel sends data. After installation, confirm that the control panel seizes the line, acquires dial tone, reports correctly to the receiver, and releases the telephone line to the in-house telephone system.

Figure 7: RJ31X Wiring

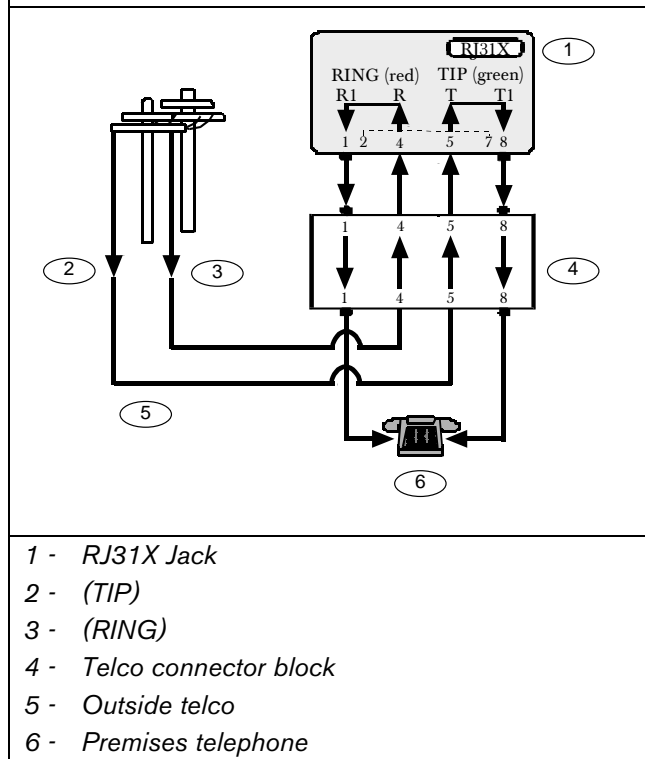

7.4 Telephone Cord Connection

Connect one end of a D161 (2.1 m [7 ft.]) or a D162 [61 cm (2 ft.)] Telephone Cord to the telco cord connector located on the bottom left corner of the control panel. Refer to *Figure 8*. Connect the other end to the RJ31X or RJ38X jack.



To supervise the phone cord, use an RJ38X jack.

Figure 8: Phone Connector, Phone LED, and Operation Monitor LED Locations

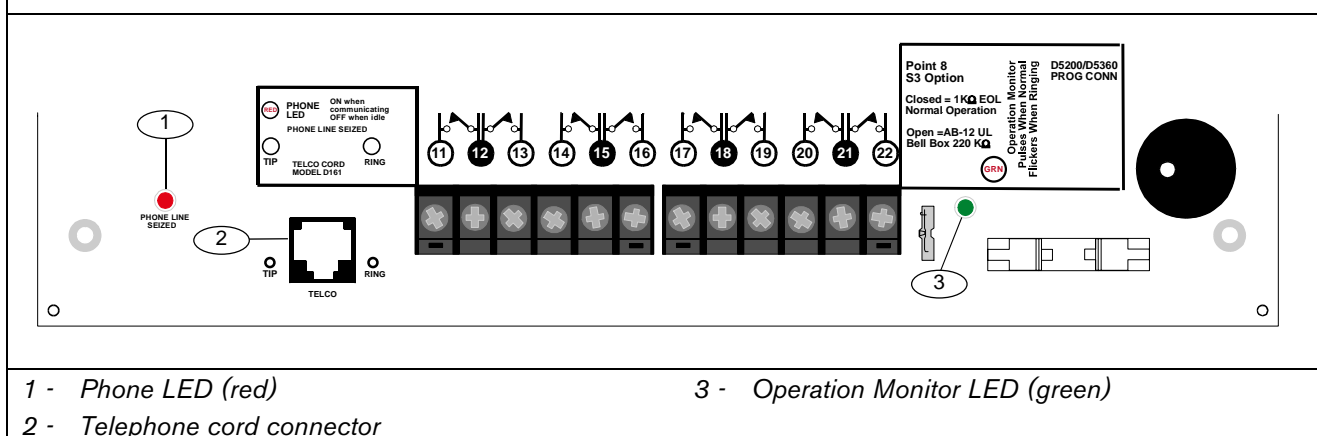

7.5 Phone LED (Red)

The red Phone LED illuminates when the control panel seizes the telephone line and remains illuminated until the control panel returns the telephone line. Refer to *Figure 8* on page 26 for the location of the red LED.

7.6 Operation Monitor LED (Green)

The green Operation Monitor LED indicates the operation of the central processing unit (CPU). When the CPU is operating normally, the LED flashes 0.5 sec on, 0.5 sec off.

This green LED also serves as a ring indicator. The LED is located on the lower right side (*Figure 8* on page 26). When there is ring voltage on the telephone line (the telephone is ringing), the green LED flashes at a faster rate for the duration of each ring. Ring voltage must reach a minimum of 45 VAC before the system detects it.

7.7 Dialing Format

The system can be programmed to use DTMF or pulse dialing. Refer to Phone Parameters in the *D7212GV2 Program Entry Guide* (P/N: F01U003804).

7.8 Telephone Line Monitor

The control panel has a built-in telephone line monitor that tests the telephone line for voltage and current. If the D928 Dual Phone Line Switcher is used to connect two telephone lines to the control panel, the control panel monitors both lines. The normal voltage on a telephone line is approximately 48 VDC (24 VDC for some telephone systems). The telephone line monitor senses trouble if voltage on the line falls to 5.0 to 7.0 VDC without a corresponding 13 mA of current.

If the monitor senses trouble, it starts a programmable telephone line trouble timer, which continues to run as long as the monitor senses trouble. It resets to zero when the control panel senses a normal line. If the timer reaches the delay time in the Phone Supervision program item, it begins a telephone line trouble response. Programming determines what the response is. Refer to *Phone Parameters* in the *D7212GV2 Program Entry Guide* (P/N: F01U003804).

Any time the control panel uses the telephone line to make a call or is on-line with RPS, it stops monitoring the telephone line during this process. When the telephone line on the control panel is no longer in use, it begins to monitor the telephone line again.

Bad Line Might Test OK: The telephone line monitor uses voltage levels to test the status of the telephone line. In some instances, a given telephone line might be out of service without affecting the voltage on the line. The telephone line monitor cannot recognize this trouble condition.

7.9 Called Party Disconnect

Telephone companies provide “called party disconnect” to allow the called party to terminate a call. The called party must go on hook (hang up) for a fixed interval before a dial tone is available for a new call. This interval varies with telephone company equipment. Control panel firmware allows for “called party disconnect” by adding a 35-second, “on hook” interval to the dial tone detect function. If the control panel does not detect a dial tone in 7 seconds, it puts the telephone line on hook for 35 seconds to activate “called party disconnect,” goes off hook, and begins a seven-second dial tone detect. If no dial tone is detected, the control panel dials the number anyway. Each time the number is dialed, the control panel records this as an attempt.

7.10 Communication Failure

After two attempts to reach the receiver, the control panel generates and sends a COMM FAIL PH # event. The event that triggered the telephone call to the central station follows the COMM FAIL PH # event.

After ten attempts to reach the receiver, the control panel enters communication failure. The control panel clears any reports in its telephone buffer and COMM FAIL RTE # event is generated, which appears in the display at keypads. A trouble sounder can be programmed to annunciate at the keypads.

One hour after the COMM FAIL RTE # is generated, the control panel attempts to send this event. If the COMM FAIL RTE # event is the only event in the queue and cannot reach the central station, the keypads do not turn on the trouble sounder again.

Enhanced Communication

The D7212GV2 Control Panel can send events over the SDI Bus to a DX4020 or D9133TTL-E Network Interface Module (NIM). For more information on the enhanced communications capabilities, refer to *GV2AUX* in the *D7212GV2 Program Entry Guide* (P/N: F01U003804).

8.0 On-Board Points

8.1 Terminals 11 to 22 Description

The control panel provides eight on-board points. Each point functions independently and does not interfere with the operation of the others. The control panel monitors the sensor loops for normal, shorted, or open conditions between an input terminal (11, 13, 14, 16, 17, 19, 20, or 22) and any of the point common terminals (12, 15, 18, and 21). Programming for the point determines how the control panel responds to those conditions. Refer to the *D7212GV2 Program Entry Guide* (P/N: F01U003804) for point programming options. The control panel also monitors the sensor loops for ground fault conditions if S4 is latched (ground fault detect enabled).

8.2 Point Sensor Loops

When wiring the on-board points (*Figure 9*), install a 1 k Ω resistor at the far end of the sensor loop to provide a reference for supervision. Dry-contact sensing devices can be connected in series (normally-closed) or in parallel (normally-open) to any of these loops.

The number of normally-open and normally-closed detection devices each sensor loop can supervise is limited only by the resistance on the loop. The total resistance for the wire length and contacts, minus the end-of-line (EOL) resistor, must not exceed 100 Ω .

8.3 Point Parameters

The condition of on-board Points 1 to 8 is determined by measuring the voltage across the point input terminal and one of the common terminals. The sensor loops must be connected and the 1 k Ω EOL resistor in place.

Table 9: Point Parameters

Loop	Voltage Range
Open	Greater than 3.7 VDC, but less than 5.0 VDC.
Normal	Greater than 2.0 VDC, but less than 3.0 VDC.
Shorted	Greater than 0.0 VDC, but less than 1.3 VDC.

Figure 9: On-board Point Sensor Loop Wiring

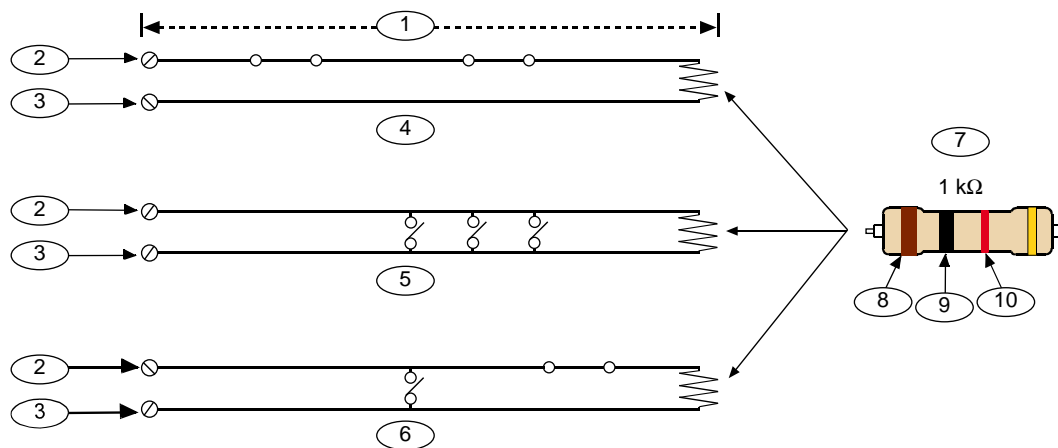

1 - 100 Ω maximum

2 - Point input terminal

3 - Common

4 - Normally-closed contacts (NC)

5 - Normally-open contacts (NO)

6 - Combination: Normally-open contacts and normally-closed contacts (NO/NC)

7 - P105F (Package of 8 EOL resistors) or P105BL (Package of 8 UL Listed EOL resistors) (P/N: 15093130-004)

8 - Brown

9 - Black

10 - Red

8.4 Point Response Time

The control panel scans on-board and off-board point sensor loops every 300 ms. The Debounce program item in the Point Assignment section of the software determines point response time by setting the number of times the control panel scans a point before generating an alarm.

The debounce count can range from 2 to 15; therefore, point response time ranges from 600 ms to 4.5 sec. The Bosch Security Systems default for debounce count is 2.



Increasing debounce might cause missed alarms. If you increase the debounce count, detection devices can enter alarm and reset without exceeding the point response time.

Use a debounce count of 2 for all points except for Interior Follower points. Program Interior Follower points as 3.

8.5 Wiring Information for Installations Using the Ademco AB-12 Bell/Housing

1. Disconnect the wire jumper from Terminal 4 to the inner housing of the Bell Box to prevent a ground fault condition.
2. Connect wiring between the control and Bell Box (*Figure 10* on page 30).

To use the AB-12 Bell/Housing, place the S3 switch in the disabled (open) position. The EOL used in the AB-12 Bell/Housing must be a 220 k Ω , 0.5 W resistor.

3. Program Point 8 as 24-hour, Alarm on, open, and short. (PT TYPE 0, PT RESPONSE 0).

Figure 10: Wiring for Installation Using the Ademco AB-12 Bell/Housing

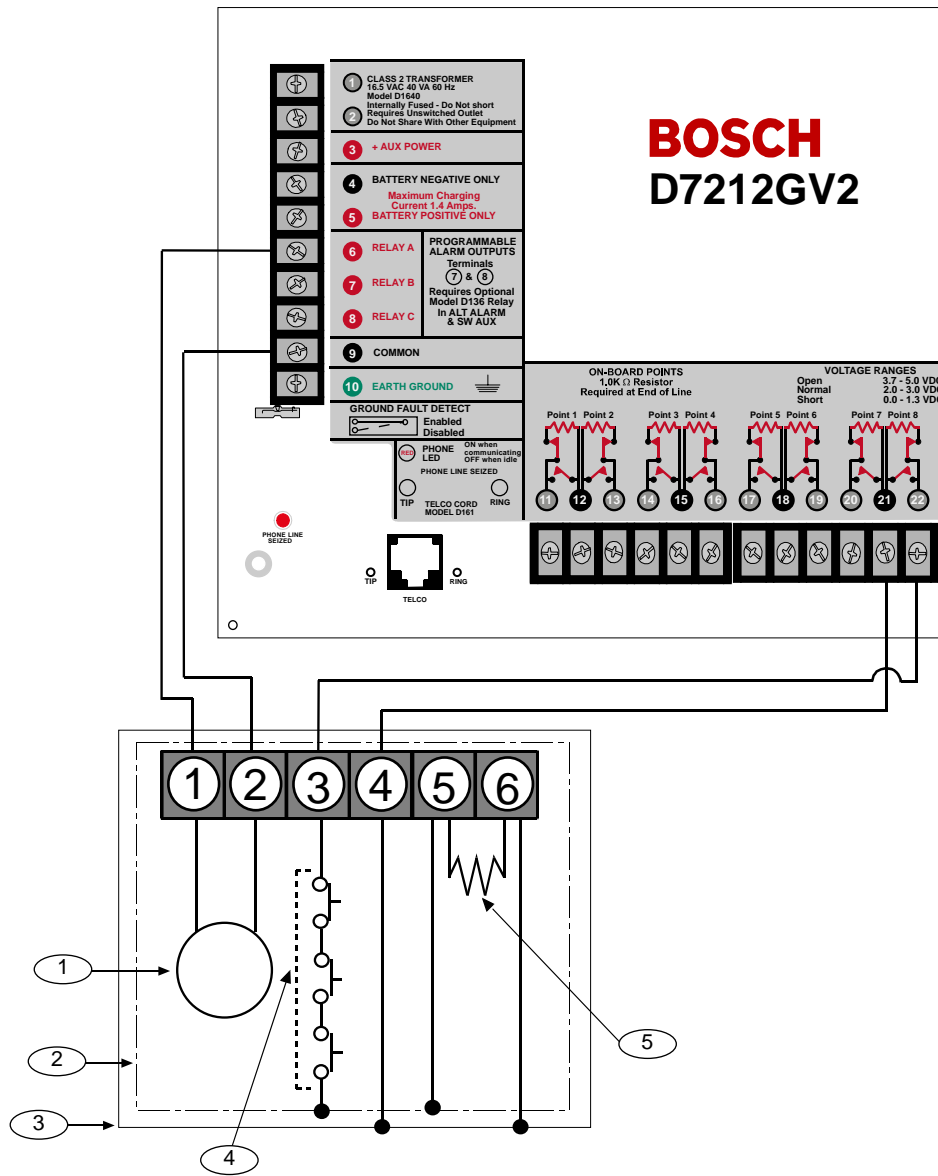

- | | |
|---------------------------|---|
| 1 - Bell | 4 - Bell tampers |
| 2 - Inner bell box lining | 5 - 220 kΩ 0.5 W EOL resistor (provided with the Ademco AB-12 Bell/Housing) |
| 3 - Outer bell box | |

9.0 Off-Board Points

9.1 Point (Zonex) Bus: D7212GV2 Terminals

9.1.1 POPIT Modules

The D7212GV2 can use point of protection input transponder (POPIT) modules to provide a maximum of 32 off-board points, bringing the total number of points the D7212GV2 can monitor to 40. Each off-board point requires a POPIT Module.

9.1.2 POPEX Modules

POPITs connect to supervised two-wire data expansion loops run from POPIT to POPIT throughout the premises. Data expansion loops connect to a D8125 Point of Protection Expander (POPEX) Module. POPEX Modules have power and data connections to the point bus on the control panel (*Table 10*).

Table 10: POPEX Modules		
Model	Power	Data
D7212G	Terminals 3 and 9	Terminals 27 and 28

9.1.3 Missing Conditions

If a programmed POPIT is disconnected from the expansion loop, a missing condition appears immediately and the event is logged. The missing condition might also be sent to a central station or printed to an on-site printer, if programmed to do so. Refer to the *D7212GV2 Program Entry Guide* (P/N: F01U003804) for programming options.

9.1.4 Extra Point Events

Extra Point events are generated when a POPIT connected to the data expansion bus does not have an assigned Point Index. *Table 11* shows when an Extra Point event is or is not generated. *Table 12* on page 32 shows additional error conditions that can occur for the off-board points.

Table 11: Extra Point Events		
A POPIT connected to the data expansion bus does not have an assigned Point Index and:	Extra Point event?	Additional Information
Data expansion bus is disconnected	No	Keypad does not annunciate or display a trouble condition.
Data expansion bus restores to normal condition after an open condition	Yes	<ul style="list-style-type: none"> Keypad annunciates and displays a trouble condition Extra Point is logged and might be programmed to send reports to the central station or to an on-site printer.
Point input changes status from normal to open or shorted	No	Keypad does not annunciate or display a trouble condition.
During a Service Walk Test, the point input changes status from normal to open or shorted	Yes*	<ul style="list-style-type: none"> Keypad annunciates and displays a trouble condition Extra Point is logged and might be programmed to send reports to the central station or to an on-site printer.

* The Service Walk Test never shows the electrical state of a point as "Extra."

Error Condition	Result	Additional Information
+/- leg of the data expansion bus has a short-circuit to earth ground, with Ground Fault Detect enabled	Ground Fault event	
+/- leg of the data expansion bus is disconnected	All POPITs beyond the disconnection send Missing report	
Data expansion bus has a short-circuit	<ul style="list-style-type: none"> All POPITs send Missing report Pt Bus Trouble event 	When the data expansion bus restores, Pt Bus Restore event occurs. If any POPIT is connected to the data expansion bus without an assigned Point Index, an Extra Point event occurs.
+/- leg of the data expansion bus has a short-circuit to the Common terminal on the D7212G	<ul style="list-style-type: none"> All POPITs send Missing report Pt Bus Trouble event 	
Terminal 28 has a short-circuit to a Common terminal	No Pt Bus Trouble event occurs	
Terminal 27 has a short-circuit to a Common terminal	<ul style="list-style-type: none"> Pt Bus Trouble event Keypad displays: SERVC ZONEX 1 	
Terminals 27 and 28 have a short-circuit together	<ul style="list-style-type: none"> Pt Bus Trouble event Keypad displays: SERVC ZONEX 1 	

9.1.5 D7212GV2 Responses to Missing Point Conditions

The D7212GV2 responds to missing point conditions based on the point's programming and the armed state of the point's area. For example, if an interior motion detector point is missing during a disarmed state, a Missing Trouble event is generated; however, if the point is missing while the area is Master Armed, a Missing Alarm event is generated. Non-fire, 24-hour points always generate a Missing Alarm event whereas Fire points always generate a Missing Fire Trouble event.

9.2 D8125, D8127 and D9127 POPIT Modules

D8127 and D9127 POPITs use the D8125 POPEX Module to report to the control panel. Points 9 to 40 connect to the POPEX Module. The control panel annunciates activity only for each POPIT, not for each detection device connected to the sensor loop.

There are two versions of the D8127 and D9127 Modules. Both module enclosures are made of UL Listed fire resistant material. D8127T and D9127T Modules contain tamper switches. D8127U and D9127U Modules include untampered covers. Unless the module is mounted in a tampered enclosure, UL requires D8127T and D9127T Modules for certificated accounts.

Listings

The D8125 POPEX and the D8127 and D9127 POPIT Modules are UL Listed for Local or Police Connected Burglar Alarm, Central Station Burglar Alarm, Household Burglar Alarm, Household Fire, and Electrically Actuated Transmitter Applications.

Refer to the *D7212GV2 Approved Applications Compliance Guide* (P/N: F01U003806) to determine the required equipment and enclosures for the application.

Figure 11: Connecting the D8125 POPEX to the D7212GV2 Panel

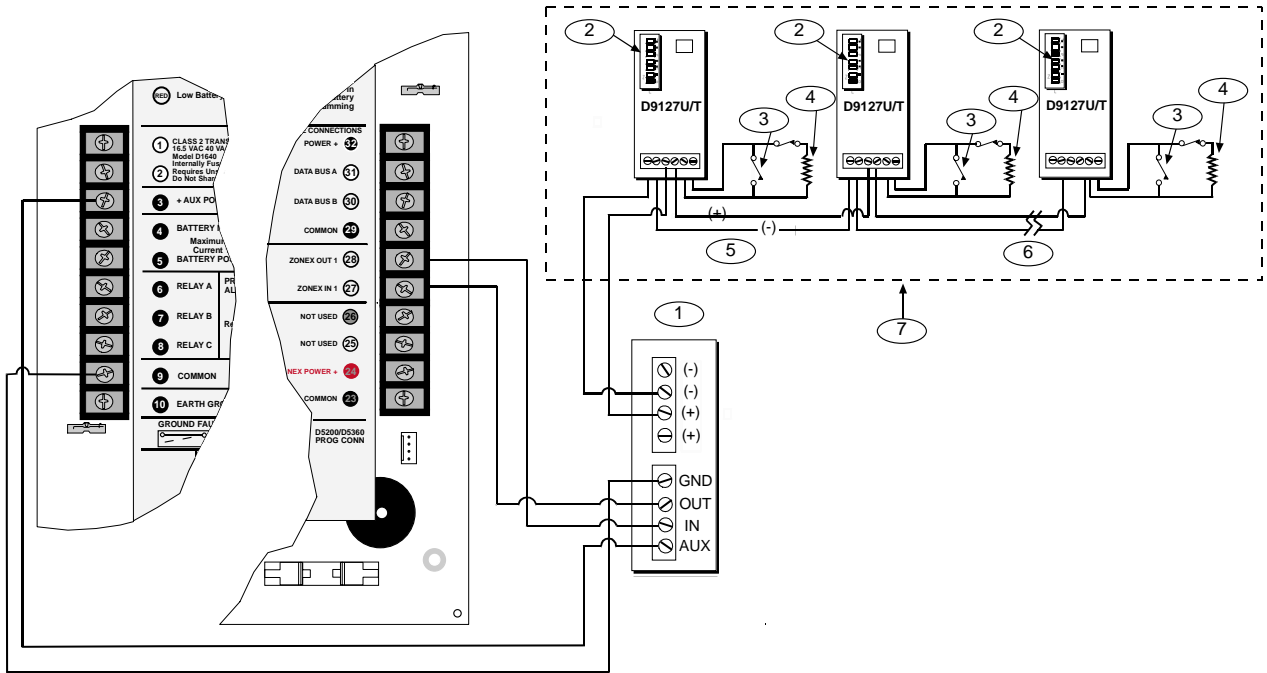

1 - D8125 POPEX Module

2 - Switch block

3 - D9127 Sensor Loop

4 - 33 kΩ EOL resistor (P/N: P106F, package of eight)

5 - Zone expansion loop

6 - Up to 67 POPITs

7 - Expansion zones

9.3 Installing the D8125 POPEX Module



For information on the Multiplex Bus Interface, refer to the *D8125 Multiplex Bus Interface Operation and Installation Guide* (P/N: 36796).

Save the POPIT Label Sheets: The D8125 is packaged with two sets of POPIT label sheets. One set is marked “Bank 1” for use with the D7412GV2 and D7212GV2. The other set is marked “Bank 2” for use with the D9412GV2 and D9112. Use the Bank 1 sheet later to label the POPITs. Refer to *Section 9.3.6 POPIT Module Point Assignments* on page 35.

9.3.1 Mounting

To install the D8125 in the enclosure with the control panel:

1. Align the D8125 POPEX Module with any of the four mounting locations in the enclosure (refer to *Figure 2* on page 14).
2. Using the screws provided with the module, secure it in the enclosure.

9.3.2 Wiring the D8125 to the Control Panel

To wire one or two D8125 Modules to the control panel (*Figure 11* on page 33):

Power Down the Control Panel

Disconnect the positive (red) battery lead at the battery and unplug the transformer.

For Points 9 to 40:

1. Connect the GND terminal of the D8125 to Terminal 9 on the D7212GV2.
2. Connect the OUT terminal of the D8125 POPEX Module to ZONEX IN 1, Terminal 27.
3. Connect the IN terminal of the D8125 POPEX Module to ZONEX OUT 1, Terminal 28.
4. Connect the AUX terminal of the D8125 to Terminal 3 on the D7212GV2.

Refer to *Section 9.3.4 Wiring Data Expansion Loops to POPEX Modules* on page 35 for instructions on connecting POPITs to the D8125 POPEX Module.

9.3.3 Wiring POPITs to the Data Expansion Loop

Use one two-wire data expansion loop or distribute the POPITs on up to three loops. Setting DIP switches on the POPIT Modules assigns them to point numbers. Refer to *Section 9.3.6 POPIT Module Point Assignments* on page 35.

Review *Section 4.6.2 Installing and Wiring Detection Devices* on page 17 to determine if shielded wire is required. Determine the wire gauge for the length of each data expansion loop using *Table 13*.

Table 13: Data Expansion Loop Wire Specifications

Maximum Length of All Data Expansion Loops Combined	
AWG	Length in Meters (Feet)
22	548 (1800)
20	881 (2890)
18	1402 (4600)
16	2231 (7320)
14	3551 (11,650)

Combine Data Expansion Loops

The maximum lengths shown in *Table 13* are for all data expansion loops connected to the same POPEX Module combined.

Wiring POPITs Together



Do **not** connect POPITs to each other in series or with a T-tap. Doing so might cause random missing POPIT conditions.



Before installing the POPITs, ensure that the resistance on the data expansion loop is no more than 40 Ω .

To connect POPITs to each other in parallel:

1. Connect the positive (+) data terminal from one POPIT to the positive (+) data terminal on the next POPIT.
2. Connect the negative (-) data terminal from one POPIT to the negative (-) data terminal on the next POPIT.
3. Repeat Steps 1 and 2 to connect all POPITs to the expansion loop. It is not necessary to wire the POPITs in any particular sequence on the loop. The switch setting on each POPIT assigns it a point number, regardless of its physical location.

Three-inch Clearance for Tampered POPITs

Mount tampered POPIT modules at least 7.6 cm (3 in.) apart to prevent the tamper magnets from interfering with each other.

9.3.4 Wiring Data Expansion Loops to POPEX Modules

Each POPEX Module has two positive (+) and two negative (-) data expansion loop terminals. Up to 32 POPITs can be connected to one D8125 on the D7212GV2 (refer to *Figure 11* on page 33).

To connect the data expansion loops to the D8125 POPEX Module:

1. Connect the positive (+) data terminal from the first POPIT on the data expansion loop to one of the D8125's positive (+) terminals.
2. Connect the negative (-) data terminal from the first POPIT on the data expansion loop to one of the D8125's negative (-) terminals.

9.3.5 POPIT Sensor Loops

The number of normally-open and normally-closed detection devices each sensor loop can supervise is limited only by the resistance on the loop. Resistance on each sensor loop must be less than 100 Ω not including the EOL resistor.

Certain UL and NFPA applications can limit the number of detection devices. Consult the appropriate UL or NFPA standards.

POPITs detect open, shorted, normal, and grounded circuit conditions on their sensor loops. They transmit the condition of their loops to the control panel. A ground on the sensor loop sends a general system ground fault condition report. Refer to *Ground Fault* in the *D9412GV2/D7412GV2/D7212GV2 Installation and Troubleshooting Quick Reference Guide* (P/N: F01U003638). Each POPIT is programmed and sends signals to the control panel separately.

Terminate each POPIT sensor loop with the 33 k Ω end-of line (EOL) resistor (D106F) included with each POPIT.

Use a twisted-pair wire (six twists per foot) in all POPEX and POPIT installations for the data expansion loop wiring and the POPIT sensor loops. Run wires away from AC sources to prevent AC induction. If you suspect a noisy environment, use shielded cable. Refer to *Section 9.3 Installing the D8125 POPEX Module* on page 34.

9.3.6 POPIT Module Point Assignments

Six switches on each POPIT assign the module to a point number. For POPIT switch settings, refer to *Point Assignment* in the *D7212GV2 Program Record Sheet* (P/N: F01U003804). The program record sheet provides information about the Point Assignments tables. *Figure 12* on page 36 is an example of the tables.



For the D7212GV2, Points 9 to 40 can use either D8127 or D9127 POPITs.

9.3.7 Program Record Sheet

The first column of the table in *Figure 12* on page 36 contains the **POPIT Switch Settings** for the D8127 POPITs. On the D8127 POPITs, the switches are numbered 1 to 6, from left to right. On the D9127 POPIT, switches are numbered 0 to 6, from left to right. Set the indicated switches to the ON position. If a dash (-) appears in the switch position, set the switch to the OFF position.

The second column contains the **Translation** of the point number into the Zonex format. Refer to *Point User Flag* in the *D7212GV2 Program Entry Guide* (P/N: F01U003804) for an explanation of this feature.

The third column contains the **Point Number** as shown at keypads.

The fourth column contains the **Point Index**. Refer to *Point Index Parameters* in the *D7212GV2 Program Entry Guide* (P/N: F01U003804) for an explanation of the point index.

The fifth column, **Area Assign**, shows the area to which the point is assigned.

The sixth column shows the **Debounce Count** for the point. Refer to *Debounce Count* in the *D7212GV2 Program Entry Guide* (P/N: F01U003804)

The seventh column shows the **BFSK/Relay** report code, which is the point number reported for this point when the control panel is using the BFSK format.

The eighth column contains the **Custom Point Text** displayed at keypads for the point. The text is sent to the receiver when the control panel uses the Modem IIIa² format.

Figure 12: Program Record Sheet

D9412GV2/D7412GV2 Program Record Sheet RADXPNTS Handler							EN 25	
Default values are shown in () or in bold								
Point Assignments (001 through 040)								
POPIT Switch Setting	Translation	Point #	Point Index	Area Assign	Debounce	BFSK/Relay	Custom Point Text	
	100	001	(3) --	(1) --	(2) --	(1) --	P1 FIRE _____	
	200	002	(1) --	(1) --	(2) --	(2) --	P2 PANIC _____	
	300	003	(25) --	(1) --	(2) --	(3) --	P3 DELAY _____	
	400	004	(13) --	(1) --	(2) --	(4) --	P4 FOLLOW _____	
	500	005	(7) --	(1) --	(2) --	(5) --	P5 INSTANT _____	
	600	006	(7) --	(1) --	(2) --	(6) --	P6 INSTANT _____	
	700	007	(7) --	(1) --	(2) --	(7) --	P7 INSTANT _____	
	800	008	(7) --	(1) --	(2) --	(8) --	P8 INSTANT _____	
0 1 2 3 4 5 6	101	009	--	(1) --	(2) --	(1) --	P9 _____	

9.3.8 POPIT Labels

D7212GV2 off-board points are numbered 9 to 40. Two sheets of peel-off POPIT labels are supplied with the D8125 POPEX Module. Use the sheet marked “Bank1” for Points 9 to 40.

Each label has two parts. Place the smaller part, with only the point number, on the chip. Place the larger part, with the switch settings, on the base of the POPIT. Set the switches and cover the POPIT.

Do **not** program two POPITs for the same point number. After programming all the points, perform a Service Walk Test. The *D9412GV2/D7412GV2/D7212GV2 Installation and Troubleshooting Quick Reference Guide* (P/N: F01U003638) contains instructions for performing a Service Walk Test. If a point does not test, check the programming for a duplicated address.

Walk Test and Service Walk Test Do Not Show

Extra Points: If the point assignment switches on a POPIT or OctoPOPIT are set incorrectly, missing and extra point conditions might occur. If the same point number is assigned to two or more POPITs or OctoPOPITs, none of the points with that number test correctly. Refer to *Section 9.1 Point (Zonex) Bus: D7212GV2 Terminals* on page 6.

9.4 D8128D OctoPOPIT Module



Use only the D8128D OctoPOPIT Module. Using Modules D8128, D8128A, or D8128B can cause intermittent MISSING and RESTORAL reports.

9.4.1 Description

The D8128D OctoPOPIT Module combines the functions of the D8125 POPEX Module and the D8127/D9127 POPIT Modules to provide eight off-board points in a single module. You can wire both D8128D OctoPOPIT and D8125 POPEX Modules in parallel to the Zonex bus terminals on the same control panel.

Review *Section 6.0 Power Outputs* on page 24 to ensure there is enough power for the OctoPOPITs and other powered devices that will be connected to the system.

Up to four D8128Ds can be connected to the D7212GV2 Control Panel (three points can be used on the last OctoPOPIT).

9.4.2 Listings

The D8128D OctoPOPIT Module is UL Listed for Local or Police Connected Burglary Alarm, Central Station Burglary Alarm, Household Burglary Alarm applications, and commercial fire applications (UL 864 and NFPA 72).

The D8128D is also suitable for fire supervisory applications, such as indicating circuit supervision (using the D192C/D192G Bell Circuit Supervision Module), sprinkler supervision, and valve tamper protection. Do not connect fire-alarm initiating device directly to D8128D.

Figure 13: D8128D OctoPOPIT Layout

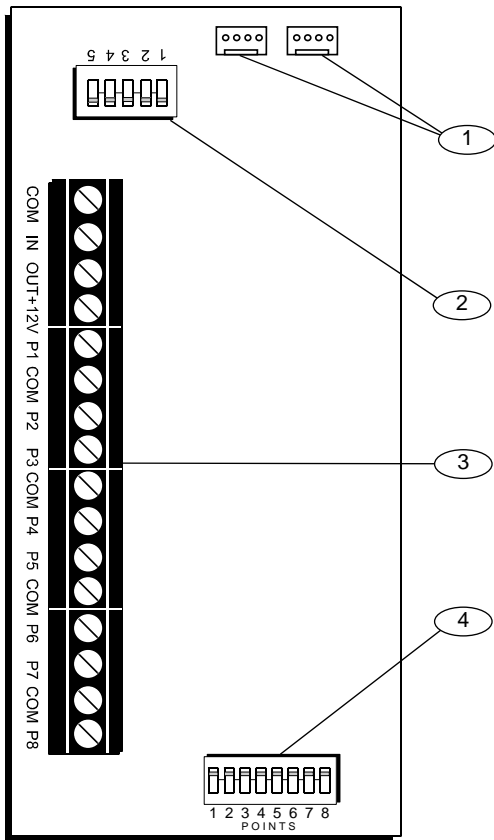

- 1 - Molex® connectors
- 2 - Address DIP switches
- 3 - Terminal strip
- 4 - Point DIP switches

9.4.3 Installation

For the most effective installation, use the following four-step process:

1. Set the OctoPOPIT switches. Refer to *Section 9.4.4 Setting the OctoPOPIT Switches*.
2. Physically mount the OctoPOPIT in the enclosure. Refer to *Section 9.4.5 Mounting OctoPOPITs* on page 38.
3. Wire the OctoPOPIT. Refer to *Section 9.4.6 Wiring OctoPOPITs* on page 38.
4. Wire the OctoPOPIT sensor loops. Refer to *Section 9.4.6 OctoPOPIT Sensor Loops* on page 41.

9.4.4 Setting the OctoPOPIT Switches

The D8128D OctoPOPIT has two sets of DIP switches (Figure 13). Use the DIP switches on the top of the unit (with the terminal strip along the left edge) to set the address for the OctoPOPIT. Use the DIP switches at the bottom of the unit to enable or disable individual points connected to the OctoPOPIT.

Address Switches

The switches on the D8128D OctoPOPIT set point assignments and line termination. These switches are easier to set before mounting the D8128D in the enclosure.

Switches 1, 2, 3, and 4 assign the OctoPOPIT sensor loops to point numbers on the control panel. Table 14 shows the OctoPOPIT switch settings for point assignments.

Switch 5 sets line termination. Refer to Table 15.

Table 14: D8128D OctoPOPIT Switch Settings

ZONEX 1 Points 9 to 40	D8128D Address Switches				
	1	2	3	4	5
9 to 16	ON	ON	ON	ON	*
17 to 24	ON	ON	ON	OFF	*
25 to 32	ON	ON	OFF	ON	*
33 to 40	ON	ON	OFF	OFF	*

* Line Termination Switch

Table 15: Switch 5 Settings for Line Termination

Is a D8125 POPEX Module connected?	Zonex No. 1	Switch 5 Setting(s) on D8128D OctoPOPIT(s)
No	NA	Set Switch 5 of only one D8128D to ON
Yes	1	Set Switch 5 of all D8128Ds to OFF
No	NA	Set Switch 5 of only one D8128D to ON
Yes	2	Set Switch 5 of all D8128Ds to OFF

Point DIP Switches

Each point connected to the D8128D is enabled by closing the respective DIP switch, or disabled by opening the DIP switch. For example, to disable a device connected to the P3 Terminal (Point 3), move DIP switch number 3 to the OPEN position.

Use the point DIP switches to disable conflicting points, such as when a D9210B Access Control Module must be assigned to a point that falls within the range of the D8128D OctoPOPIT. In this example, a D9210B is assigned to Point 20. On the same system, a D8128D OctoPOPIT is assigned to Points 17 through 24. Moving the DIP switch for Point 4 to the OFF position would effectively disable Point 20, allowing normal operation of the D9210B and the OctoPOPIT.

Terminate each OctoPOPIT sensor loop with a 1 k Ω EOL resistor. Attach a resistor even if you do not enable the loop.

9.4.5 Mounting OctoPOPITs

The D8128D OctoPOPIT Module can be installed in the enclosure with the control panel using standard four-conductor 0.8 mm (22 AWG) wire, or in a separate enclosure (Model D8103, D8103A, or D8109) up to 61 m (200 ft.) from the control panel using shielded (recommended) standard four-conductor 0.8 mm (22 AWG) wire. If using the D125B or D129, refer to the *Specifications* section of the *D8128D Installation Guide* (P/N: 41323) for cabling requirements.

For UL Listed systems, mount the D8128D in a tamper-proof enclosure. To install OctoPOPITs in the control panel's enclosure, complete the following procedure. Use the D137 Mounting Bracket to install OctoPOPITs in enclosures with no module-mounting locations available.

1. Align the OctoPOPIT module using any of the four mounting locations in the enclosure. Refer to *Figure 2* on page 14.
2. Use the screws provided with the module to secure it in the enclosure.

9.4.6 Wiring OctoPOPITs



Warning: Disconnect all power to the control panel before beginning any work with the internal components. Serious injury could result from electrical shock.

1. Power down the control panel:
 - a. Disconnect the positive (red) battery lead at the battery.
 - b. Unplug the transformer.



A D8128D OctoPOPIT can be installed up to 61 m (200 ft.) from the control panel.

2. Connect the D8128D to the control panel:

- Wire the D8128D to the terminal strip on the side of the POPEX Module (refer to *Using the Terminal Strip* on page 38), **or**
- Connect the D8128D using the Molex[®] connectors (P1 and P2). Refer to *Using Molex[®] Connectors* on page 40.



Caution - AC induction: Avoid installing Zonex data wires and Zonex input (sensor loop) wires around any AC conduit, wiring, or electrical devices that emit fields of electromagnetic interference (EMI).

Using the Terminal Strip

Refer to *Table 16* on this page and *Figure 14* on page 39, when using the terminal strip to connect the D8128D OctoPOPIT to the control panel.

Table 16: Terminal Strip Connections

D8128D	D7212GV2
Common	Terminal 9
Out	Terminal 27
In	Terminal 28
+12 V	Terminal 3

Figure 14: Connecting D8128D OctoPOPITs to the D7212GV2

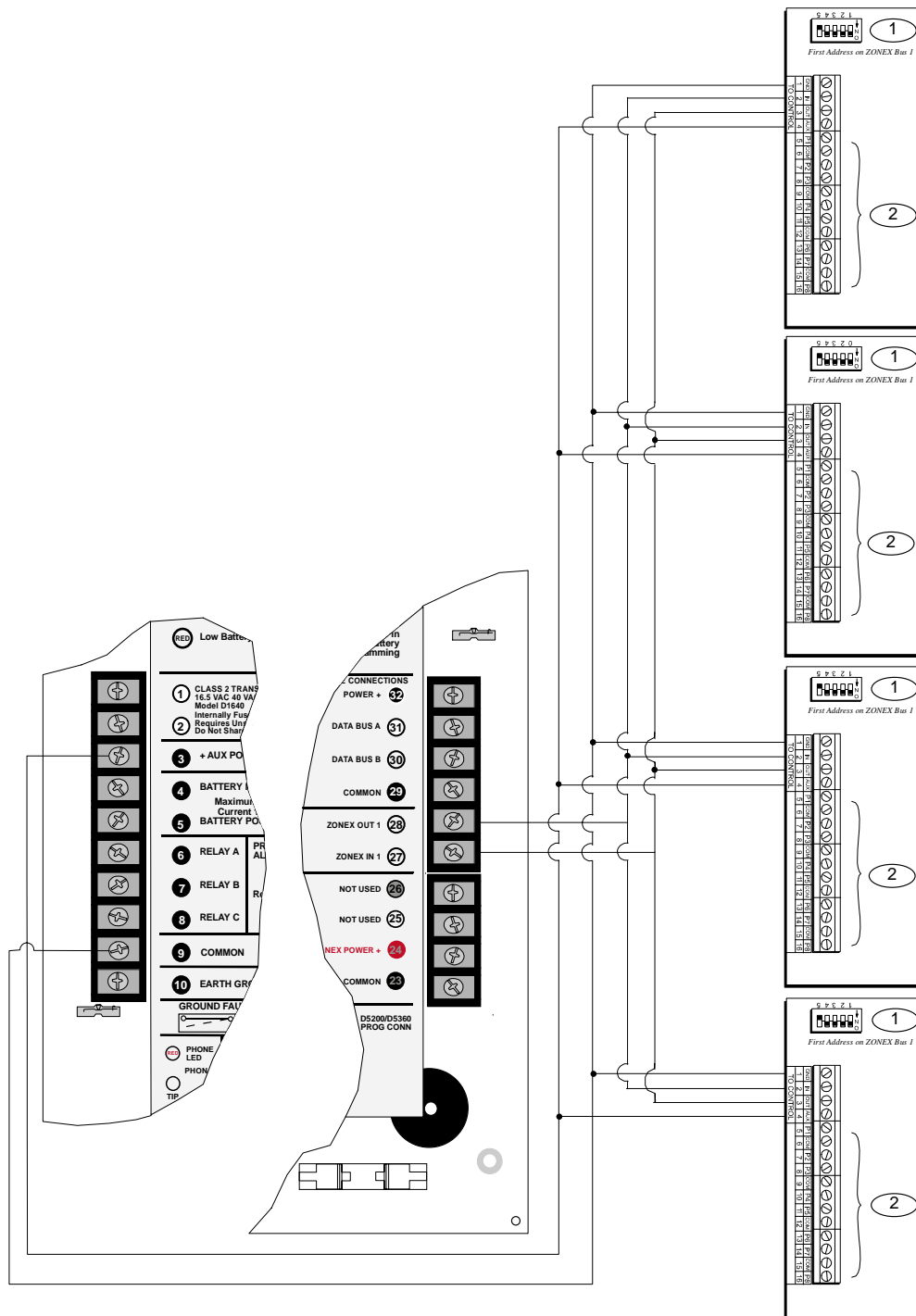

1 - First address on Zonex Bus 1

2 - Sensor loops



Refer to *Address Switches* in Section 9.4.4 *Setting the OctoPOPIT Switches* on page 37 for information about making these switch settings. Refer to *Table 15* on page 37 for information about setting Switch 5.

Using Molex[®] Connectors

Each D8128D Module is supplied with a 30 cm (12 in.) female-to-female Molex cable assembly.

P1 and P2 are Molex connectors that parallel the COM, IN, OUT, and +12 VDC terminals on the terminal strip. In installations with multiple D8128Ds, use these connectors (as opposed to terminals) with the supplied cable; however, when connecting D8128D Modules directly to the control panel, the terminal strip is easier to use.

The Molex connectors provided are "keyed" (Molex plug can only fit in one direction). Ensure the connector is attached correctly: the red wire is on the bottom of P1 (or P2) and the black wire is on the top.

When connecting multiple D8128Ds to a control panel, you can connect the control panel terminals to P1 or the COM, IN, OUT, and +12V terminals on the first D8128D. Then connect P2 of the first D8128D to P1 of the second D8128D and so on (*Figure 15*).

Figure 15: Wiring Multiple D8128Ds Using Molex[®] Connectors

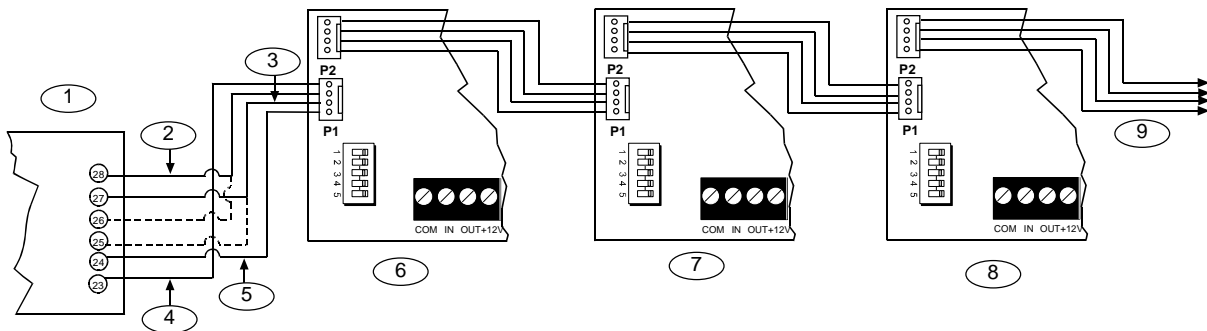

- 1 - D7212GV2 Control Panel
- 2 - Yellow
- 3 - Green
- 4 - Black
- 5 - Red

- 6 - First D8128D
- 7 - Second D8128D
- 8 - Third 8128D
- 9 - Up to 15 per Zonex Bus

9.4.7 OctoPOPIT Sensor Loops

Only the resistance on the loop limits the number of normally-open or normally-closed detection devices each sensor loop can supervise. Resistance on each sensor loop must be less than 100 Ω with the detection devices connected.

Certain UL and NFPA applications can limit the number of detection devices. Consult the appropriate UL or NFPA standards.

The OctoPOPIT detects open, short, closed, normal, and grounded circuit conditions on its sensor loops and sends the conditions to the control panel. Each sensor loop is assigned a point number and sends signals to the control panel separately.

Use twisted-pair wire for the OctoPOPIT sensor loops to avoid EMI problems. Run wires away from the premises telephone and AC wiring. If you suspect a noisy environment, use shielded cable.

The OctoPOPIT has two rows of terminal numbers. In the row nearest to the terminal blocks, the positive outputs for the sensor loops are labeled P1 to P8. Sensor loop outputs P1 and P2, P3 and P4, P5 and P6, and P7 and P8 share common terminals. The common terminals for each pair are labeled COM.

Terminate each OctoPOPIT sensor loop with a 1 k Ω EOL resistor. Attach a resistor even if you do not enable the loop. The OctoPOPIT includes a D105BL resistor for each sensor loop. Refer to *Figure 16*.

Do not duplicate point assignments. Points do not function properly if assigned to both an OctoPOPIT sensor loop and a POPIT, two OctoPOPIT sensor loops, or to two POPITs.

Figure 16: D8128D OctoPOPIT Sensor Loops

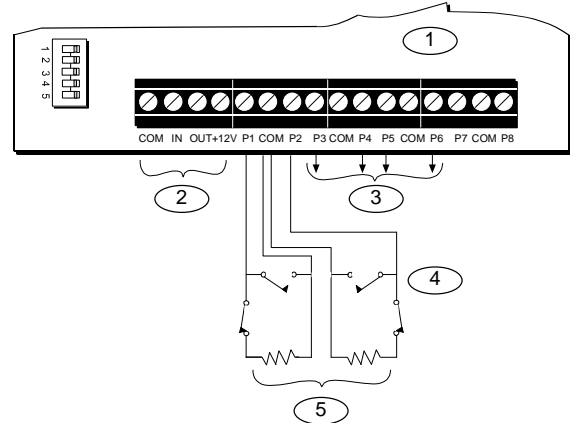

- 1 - D8128D OctoPOPIT
- 2 - To control panel
- 3 - To additional OctoPOPIT sensor loops
- 4 - OctoPOPIT sensor loops
- 5 - 1 k Ω EOL resistor (P/N: P105BL, package of eight)

9.5 Testing Off-Board Points

Use the Service Walk Test to test off-board points. Refer to the *D9412GV2/D7412GV2/D7212GV2 Installation and Troubleshooting Quick Reference Guide* (P/N: F01U003638) for instructions. Test to ensure that all off-board points operate properly.

Walk Test and Service Walk Test Do Not Show Extra Points: If the point assignment switches on a POPIT or OctoPOPIT are set incorrectly, missing and extra points can occur. If the same point number is assigned to two or more POPITs or OctoPOPITs, none of the points with that number test correctly. Refer to *Section 9.1 Point (Zonex) Bus: D7212GV2 Terminals* on page 31.

10.0 Off-Board Relays

10.1 D8129 OctoRelay

Use the D8129 OctoRelay to add relay outputs to the system in groups of eight. The D7212GV2 allows up to 24 relay outputs. Review *Section 6.0 Power Outputs* on page 24 to ensure that enough power is provided for the OctoRelays and other powered devices that are connected to the system.

OctoRelays for relay numbers 1 to 24 connect to Zonex 1, Terminal 28. Refer to *Figure 17* on this page.

Alarm output, auxiliary relay, sensor reset, arming status, point status, alarm memory, or remote functions can be assigned to the OctoRelay outputs individually. Refer to *Relay Parameters* in the *D7212GV2 Program Entry Guide* (P/N: F01U003804) for programming details.

D8129 Restricted for Fire Systems: D8129 relay outputs are not supervised and cannot be used in fire or combined fire and burglary installations for primary indicating devices.

10.2 Configuring the D8129 OctoRelay

Five switches on the OctoRelay determine the relay numbers for the eight relay outputs (*Table 17*).

Table 17: D8129 OctoRelay Switch Settings

Panel Relay Number	D8129 OctoRelay Switch Setting	On Panel, Connect D8129 to:
1 to 8	Off-On-On-On-On	Zonex 1 Terminal 28
9 to 16	On-Off-On-On-On	Zonex 1 Terminal 28
17 to 24	Off-Off-On-On-On	Zonex 1 Terminal 28

Figure 17: D8129 Connections to the D7212GV2

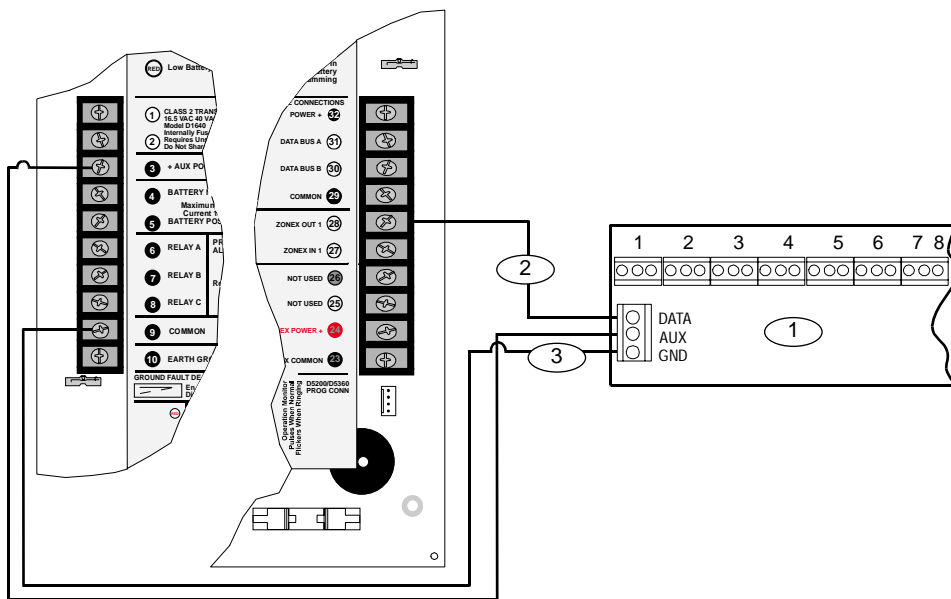

1 - D8129 OctoRelays for relay numbers 1 to 24. Connect OctoRelays in parallel.

2 - Power limited

3 - Supervised, power limited

10.3 Relay Outputs



Relay outputs can activate when you are setting the OctoRelay switches or programming the control panel.

Disconnect equipment connected to relay outputs when you perform these functions.

Each OctoRelay output provides a Form C dry contact rated for 1.0 A at 12 VDC. Normally-open, common, and normally-closed terminals are available for each relay output. When an individual output is activated, continuity exists between the normally-open and common terminals. When the output is not activated, continuity exists between the normally-closed and common terminals.

10.4 Installing OctoRelays

Set the switches on the OctoRelay before installing it in the enclosure. Refer to *Section 10.2 Configuring the D8129 OctoRelay* on page 42.

Install the OctoRelay in the enclosure with the control panel (*Figure 2* on page 8) or in an adjacent enclosure that is no more than 1.5 m (5 ft.) from the control panel. Use 1.5 mm (16 AWG) to 0.8 mm (22 AWG) wire.

To install OctoRelays in the enclosure with the control panel:

1. Align the module with one of the mounting locations in the enclosure (refer to *Figure 2* on page 8).
2. Using the screws provided with the module, secure the module in the enclosure.

Use the D137 Mounting Bracket or D9002 Mounting Skirt to install OctoRelays in enclosures with no available module mounting locations.

10.5 Wiring Connections

Power down the control panel to connect OctoRelays. Refer to *Figure 17* on page 42.



OctoRelays for Relays 1 to 24 connect to Zonex 1, Terminal 28.

Only one OctoRelay is shown wired to each Zonex bus in *Figure 17* on page 42. Wire additional OctoRelays in parallel. Review *Section 6.0 Power Outputs* on page 24 for information about providing enough power for the relays.

11.0 Arming Devices

11.1 Description

Keypads, maintained or momentary contact keyswitches, or a combination of the two are used to arm and disarm areas. The control panel can contain up to four areas. Refer to 3.3.6 *Areas and Accounts* on page 11 for a description of areas.

11.2 Keypad Terminals 29 to 32

The Bosch Security Systems keypad is a four-wire powered device used to arm and disarm areas, announce complete system status, initiate system tests, and control many functions of the security system.

The system can supervise up to eight keypads. The control panel sends a Serial Device Trouble Report, SDI FAILURE, in the Modem IIIa² format or TROUBLE ZN D in the BFSK format, if it loses communication with a supervised keypad. CALL FOR SERVICE appears in any keypad that loses communication with the control panel, if the keypad has text display capability. SERVC KEYPAD appears at all other keypads connected to the system.

A total of 32 unsupervised keypads can be connected to the system. The number of supervised keypads, number of areas, and the available power affect the total number of keypads that can be connected to the system. Refer to *Keypad* in the *D7212GV2 Program Entry Guide* (P/N: F01U003804) for complete programming details on keypad options.

Five types of keypads are available for use with the system.

- D1255 – 16-character alphanumeric display for general use.
- D1256 – text display keypad with keys designated for local fire alarm control.
- D1257 – text display keypad for fire annunciation.
- D1260 – easy-to-read, 4-line by 20-character LCD display with eight “soft” keys to display simple selections.
- D720 – LED display keypad appropriate for use as a single area keypad with up to eight points.



D1255 and D720 are available in white (D1255W and D720W) or red (D1255R and D720R).

For operational information, refer to the user’s guide for the specific keypad.

11.2.1 Assigning an Address for the Keypad

Switches on the keypad assign an address (1 to 8). The address determines if the keypad is supervised, the scope of the keypad, and to what area the keypad is assigned. Refer to *Keypad Assignment* in the *D7212GV2 Program Entry Guide* (P/N: F01U003804) for a complete description of addresses.

Table 18 shows the correct switch setting for each address.

Address	Switch					
	1	2	3	4	5	6
Address #1	ON	ON	ON	ON	Tone ON/OFF Encoding	ON
Address #2	OFF	ON	ON	ON		ON
Address #3	ON	OFF	ON	ON		ON
Address #4	OFF	OFF	ON	ON		ON
Address #5	ON	ON	OFF	ON		ON
Address #6	OFF	ON	OFF	ON		ON
Address #7	ON	OFF	OFF	ON		ON
Address #8	OFF	OFF	OFF	ON		ON

11.2.2 Installation

Refer to the keypad installation manuals for installation and mounting instructions. Keypads connect to the control panel in parallel (Table 19).

D9412GV2 Terminal	Function	Keypad Wire Color	Function
32*	POWER +	Red	12 VDC
31	DATA BUS A	Yellow	Data – In
30	DATA BUS B	Green	Data – Out
29	COMMON	Black	Common
* Connect with at least 1.5 m (5 ft.) or 0.8 mm (22 AWG) wire (4.3 m [14 ft.] of 1.2 mm [18 AWG] wire).			

Switching the Green and Yellow Wires Affects

Other Keypads: Connecting the green wire incorrectly from the keypad to Terminal 31 and the yellow wire to Terminal 30 causes other keypads connected to the control panel to go blank or to sound random beep tones.

You can connect devices to the data bus (Terminals 30 and 31) by parallel wire run from the control panel to each device, wire from device to device, or a combination of the two using a maximum of 4572 m (15000 ft.) of 0.8 mm (22 AWG) wire for all devices connected to the SDI Bus combined.

Wire Limits for Individual Keypads

- Limit most keypads to 610 m (2000 ft) per run.
- Limit D9210B Modules to 457 m (1500 ft) per run (762 m [2,500 ft] if using an external power supply).
- Limit D9131A Modules to 305 m (1000 ft) per run.

Extra Power for More Keypads

The D1255 Command Center draws 104 mA when idle. It draws 206 mA with the keys lit and the sounder activated. Review *Section 6.0 Power Outputs* on page 23 to determine the total power output requirements for the system.

One or more D8132 Battery Charger/Power Supply Modules can be added for the number of keypads used. *Figure 18* shows the D8132 powering keypads in a stand-alone configuration.

For UL Certificated accounts, use a UL Listed auxiliary 12 VDC or 24 VDC regulated, power-limited power supply for Fire Protective Signaling Units and Commercial or Residential Burglar Units. The D8132 is not UL Listed as a stand-alone power supply.



The control panel and the D8132 (or other power supply) must share COMMON.

Figure 18 shows the common form of the D8132 Module connected to the common on the keypad and the common on the control panel. Any stand-alone power supply, powering any device connected to the control panel, must also be connected to a common terminal on the control panel.

If using the ground fault detection capability on the D7212GV2 Control Panels with an external power supply, ensure that the external selected power supply isolates its earth ground connection from the negative side of the auxiliary power output. External power supplies that do not isolate earth ground can cause ground fault conditions on the control panel.

Figure 18: Power at Keypads

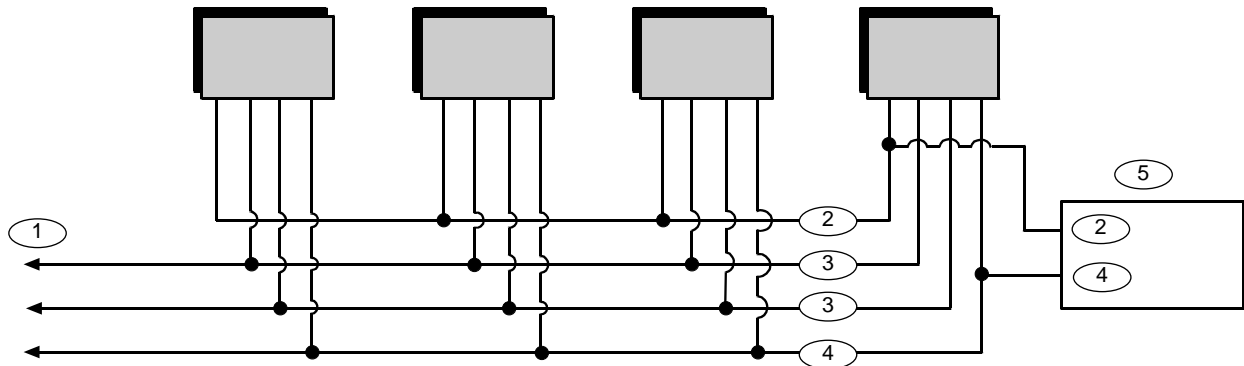

- 1 - To control panel
- 2 - +12 VDC
- 3 - Data
- 4 - Common
- 5 - D8132 or external power supply

11.3 D268/D269 Independent Zone Control, D279A Independent Zone Control

Any on-board or OctoPOPIT point can be programmed so that the D268/D269 or D279A Independent Zone Control operates as independent point control (arming and disarming the point).

Refer to *Point Assignments* in the *D7212GV2 Program Entry Guide* (P/N: F01U003804) for programming information. Refer to the *D268/D269 Operation and Installation Instructions* (P/N: 74-004758-000) or the *D279A Operation and Installation Instructions* (P/N: 46458) for wiring and operation instructions.

11.4 Keyswitch

11.4.1 Description

A maintained or momentary contact arming station (keyswitch) can be connected to master arm or disarm any of the areas in the system. The keyswitch is connected to an on-board or off-board point's sensor loop. Relays can be programmed to activate arming status LEDs for keyswitch arming stations. Refer to *Relays* in the *D7212GV2 Program Entry Guide* (P/N: F01U003804)

11.4.2 Programming

Refer to *Point Assignments* in the *D7212GV2 Program Entry Guide* (P/N: F01U003804) for the correct programming for points used for keyswitches.

11.4.3 Installation

For maintained switches, connect the EOL resistor for the point at the keyswitch so that the switch opens the circuit when it operates. A short on the circuit produces an alarm if the area is armed and a trouble if it is disarmed. Refer to *Figure 19*.

For momentary keyswitches, connect the EOL resistor at the keyswitch point so that when the keyswitch operates, it shorts the resistor. An open on the circuit causes an alarm if the area is armed and a trouble if it is disarmed. Refer to *Figure 19*.

Figure 19: Keyswitch Wiring

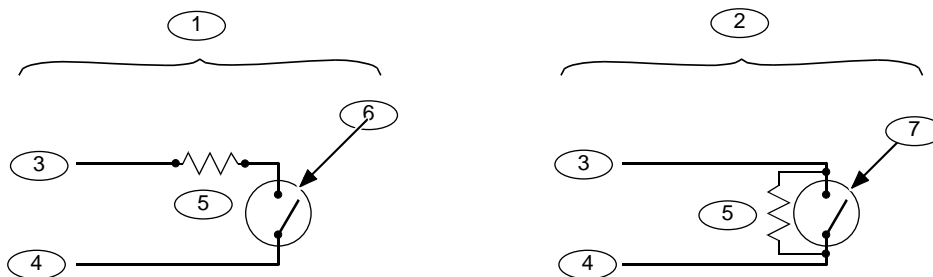

1 - Maintained keyswitch

2 - Momentary keyswitch

3 - Common

4 - Point input

5 - 1 k Ω or 33 k Ω resistor*

6 - Open on a circuit arms the area

7 - Short on a circuit toggles the arming state

* Use 1 k Ω EOL resistors if using one of the zones on the control panel or an OctoPOPIT. Use a 33 k Ω resistor if using a POPIT.

Maintained Contact

If the point to which the keyswitch is connected is programmed for a maintained contact, an open on the arming circuit arms the area. All faulted points are force armed, regardless of the entry in the FA Bypass Max program item. Returning the circuit to normal disarms the area. Refer to *Area Parameters* and *Point Assignments* in the *D7212 Program Entry Guide* (P/N: F01U003804)

Momentary Contact

If the point to which the keyswitch is connected is programmed for a momentary contact, shorting the arming circuit toggles the area's arming state between armed and disarmed. All faulted points are force armed, regardless of the entry in the FA Bypass Max program item. Refer to *Point Assignments* in the *D7212GV2 Program Entry Guide* (P/N: F01U003804).

Silencing the Bell

To silence the bell (stop Alarm Bell output) if the system is armed, position the keyswitch to disarm the area. If the area is disarmed, turn the keyswitch once to start the arming process. Turning the keyswitch a second time stops the arming process and silences the bell.

12.0 SDI Devices

12.1 Description

The D7212GV2 Control Panel can support a number of accessory devices from the SDI Bus using Terminals 29 through 32. Some devices include the D1255 Command Center (keypad) (refer to *Section 11.0 Arming Devices* on page 44), D9131A Parallel Printer Interface Module, D9210B Wiegand Control Interface Module, DX4010i RS-232 Serial Interface Module, D9133 Serial Interface Module, DX4020 Network Interface Module, and D9133TTL-E Network Interface Module.

12.2 Installation

For complete installation instructions, consult the operation and installation guide for the specific SDI device. SDI devices connect to the control panel in parallel (*Table 20*).

These devices can share power with the control panel or be powered by a stand-alone power source.

D7212GV2		SDI Devices	
Terminal	Function	Wire Color	Function
32	POWER +	Red	+12 VDC
31	DATA BUS 1	Yellow	Data – In
30	DATABUS B	Green	Data – Out
29	COMMON	Black	Common



A stand-alone power supply powering the SDI device must also be connected to a common terminal on the control panel.

Do not connect the earth ground for the stand-alone power supply to Terminal 10 on the control panel.

12.3 D9131A Parallel Printer Interface Module

The Bosch Security Systems D9131A Parallel Printer Interface Module is a four-wire powered device used to connect a standard parallel printer to a control panel. The D7212GV2 can supervise one printer. A separate D9131A Parallel Printer Interface Module is necessary for each printer. The D9131A connects to the printer using a standard parallel printer cable.

12.3.1 Switch Settings

Switches on the D9131A assign a unique address (17 to 19) for each printer. The address determines if the printer is supervised, the area scope of the printers, and the area to which the printer is assigned. Refer to *Printer Parameters* in the *D7212GV2 Program Entry Guide* (P/N: F01U003804) for a complete description of addresses.

Table 21 shows the correct switch setting for each address.

Printer	Switch					
	1	2	3	4*	5	6
17	ON	ON	ON	ON	ON	ON
* Switch 4: ON = Header and form feed OFF = No header and form feed						

12.3.2 Supervision

Supervision includes:

- Proper operation of the SDI bus
- Proper connection of the printer cable between the printer and the D9131A
- Printer paper supply
- Printer selected (on-line)
- Printer power.

The control panel sends an SDI Failure Report to the receiver if communication with the printer interface fails. If an SDI failure occurs, `SERVC PRINTER` appears at the keypad. The report to the receiver includes the address of the troubled D9131A to indicate which printer needs service.

If an SDI device is supervised and Terminal SDI A becomes disconnected, the device can continue to operate normally, depending upon environmental conditions.

12.4 SDI Address 80

SDI Address 80, available on the D7212GV2 Control Panel, allows for two-way SDI to RS-232 information. This address is used with home or building automation software. A D9133 Serial Interface Module is required for this application.

12.4.1 Serial Interface Modules (SIMs)

The DX4010i RS-232 Serial Interface Module and the D9133 Serial Interface Module are four-wire powered SDI devices that connect RS-232 devices to the D7212GV2 Control Panel. They use a specific communication protocol that is provided upon request. Contact Bosch Security Systems Technical Support Monday through Friday from 5 AM to 5 PM EST at 888-886-6189.

The DX4010i can be installed up to 305 m (1000 ft.) from the control panel, using 0.8 mm (22 AWG) wire. The DX4010i was not investigated by UL. Do not use DX4010i in UL Listed installations.

The D9133 can be installed up to 305 m (1000 ft.) from the control panel using 1.2 mm (18 AWG) wire. The D9133 was not investigated by UL. Do not use D9133 in UL Listed installations.

12.4.2 Address Settings

No jumper settings are required for the D9133 (SDI Address 80) for home or building automation purposes (Figure 20). Remove the jumper shunts for this purpose.

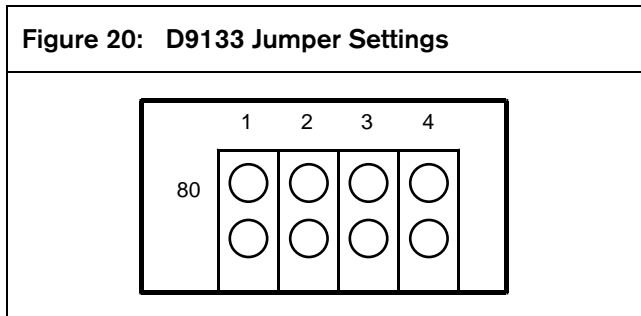

The DX4010i has specific DIP switch settings for SDI Address 80 when home or building automation is desired. Figure 21 shows the correct settings for Address 80.

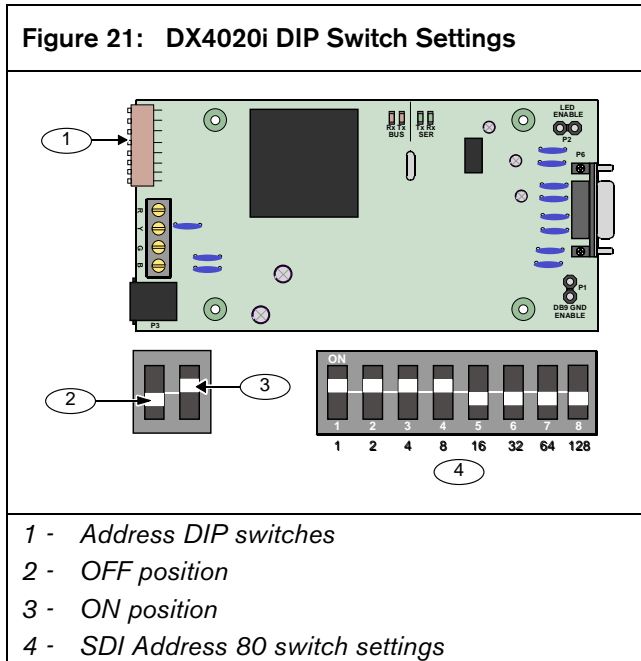

12.4.3 Supervision

Supervision of the serial interface module is available through programming. Supervision of the serial interface module is available through programming. Supervision is not required to use a DX4010i or a D9133.

If supervised, and the serial interface module does not respond to control panel supervision polls, the control panel sends an SDI Failure Report to the receiver. If it fails to communicate with the DX4010i or the D9133, SERVC SDI 80 displays at the keypad. The SDI Failure Report includes the address of the troubled module indicating which module needs service.

12.5 SDI Address 88

SDI Address 88 is available with the D7212GV2 Control Panel and is used for several different applications. When using SDI Address 88, connect only one listed device at a time.

12.5.1 D9133DC Direct Connect Programming Module

Use the D9133DC Direct Connect Programming Module to handle local programming of the D7212GV2 Control Panel. In addition, the D9133DC allows diagnostic and history retrieval. D9133DC is not UL Listed.

Connecting the D9133DC

1. Configure D9133DC for SDI Address 88. To program the control panel when the reset pin is in the unlocked position, program Enable SDI RPS to **Yes** in the GV2AUX handler.
2. Connect D9133DC to Com Port 1 or Com Port 2 on the PC. The D9133DC has a DB-9 female serial connector. A null-modem cable must be purchased separately to connect the D9133DC to a PC.
3. Using 0.8 mm (22 AWG) or 1.2 mm (18 AWG) wire, connect the D9133DC SDI terminals (SDI PWR, SDI A, SDI B, and SDI COM) to the control panel's SDI terminals (Terminals 29 to 32).

To send or receive the control panel's program, place the Reset Pin in the **Locked** or **Unlocked** position.

Locking the Reset Pin when programming the control panel improves the uploading and downloading times.

Used as an External Modem

The D9133DC can operate as an external modem when using Remote Programming Software (RPS) with the control panel. Refer to the *D7212GV2 Program Entry Guide* (P/N: F01U003804) for programming details.

12.5.2 Network Interface Modules

The Bosch Security Systems DX4020 Network Interface Module and D9133TTL-E Network Interface Module are four-wire powered SDI devices that provide connection for two-way communication over Ethernet networks to the D7212GV2.

For programming information on enhanced communications, refer to the *D7212GV2 Program Entry Guide* (P/N: F01U003804).

The DX4020 can be installed up to 305 m (1000 ft) from the control panel using 0.8 mm (22 AWG) wire.

The D9133TTL-E can be installed up to 305 m (1000 ft) from the control panel using 1.2 mm (18 AWG) wire.

12.5.3 Address Settings

The DX4020 has specific DIP switch settings for SDI Address 88 when using the DX4020 for Remote Programming Software (RPS) or enhanced communications in a LAN or WAN environment. Refer to *Figure 22* for the correct switch settings.

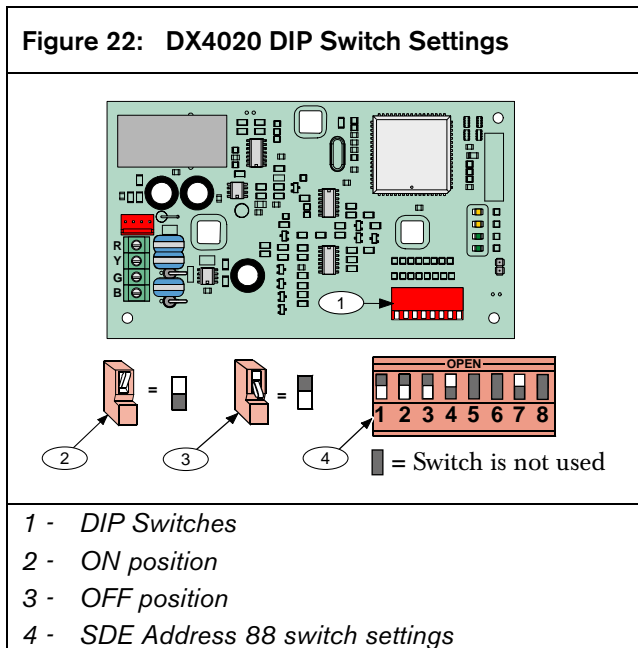

Place a jumper over Pin 8 for the D9133TTL-E (SDI Address 88) to be used for RPS or enhanced communications in a LAN or WAN environment.

Figure 23: D9133TTL-E Jumper Settings

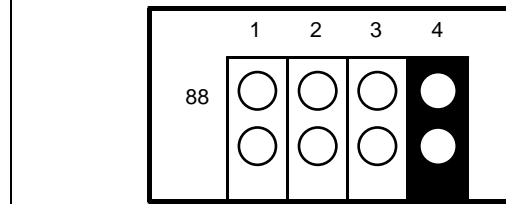

12.5.4 Supervision

Supervision of the D9133DC, D9133TTL-E, and D9133TTL-TR at SDI Address 88 is available through programming that ensures operation between the module and the control panel.

If supervised and the module does not respond to control panel supervision polls, SERVC SDI 88 appears at the keypad. The report to the receiver includes the address of the troubled module indicating which module needs service.

13.0 Programmer Connections

13.1 Programmer Connector

Refer to the *D5200 Operation Manual* (P/N: 74-06176-000) for complete information on using the D5200 programmer.

To connect and disconnect the programmer:

1. Lock the Reset Pin (*Figure 24*).
2. Connect the D5200 Data/Power cord to the programming connector on the control panel.
3. Perform the desired programming function (send or receive program).
4. Disconnect the programmer.

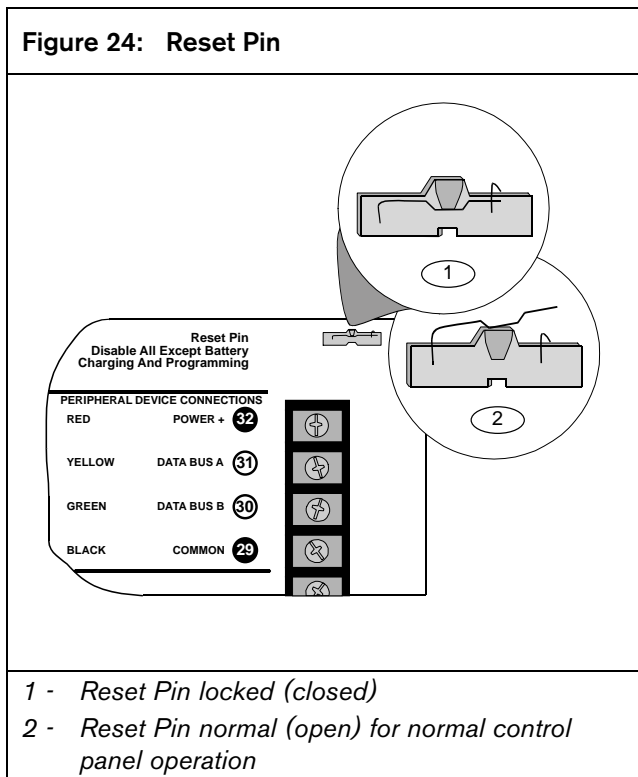

13.2 Programmer Access Reports

When a program is sent to the control panel, the control panel sends a `Prog Access OK` report ten seconds after the handler exits or when the programmer disconnects. The prompt in routing must be programmed **Yes** to send this report.

14.0 D7212GV2 Faceplate

Figure 25: D7212GV2 Faceplate

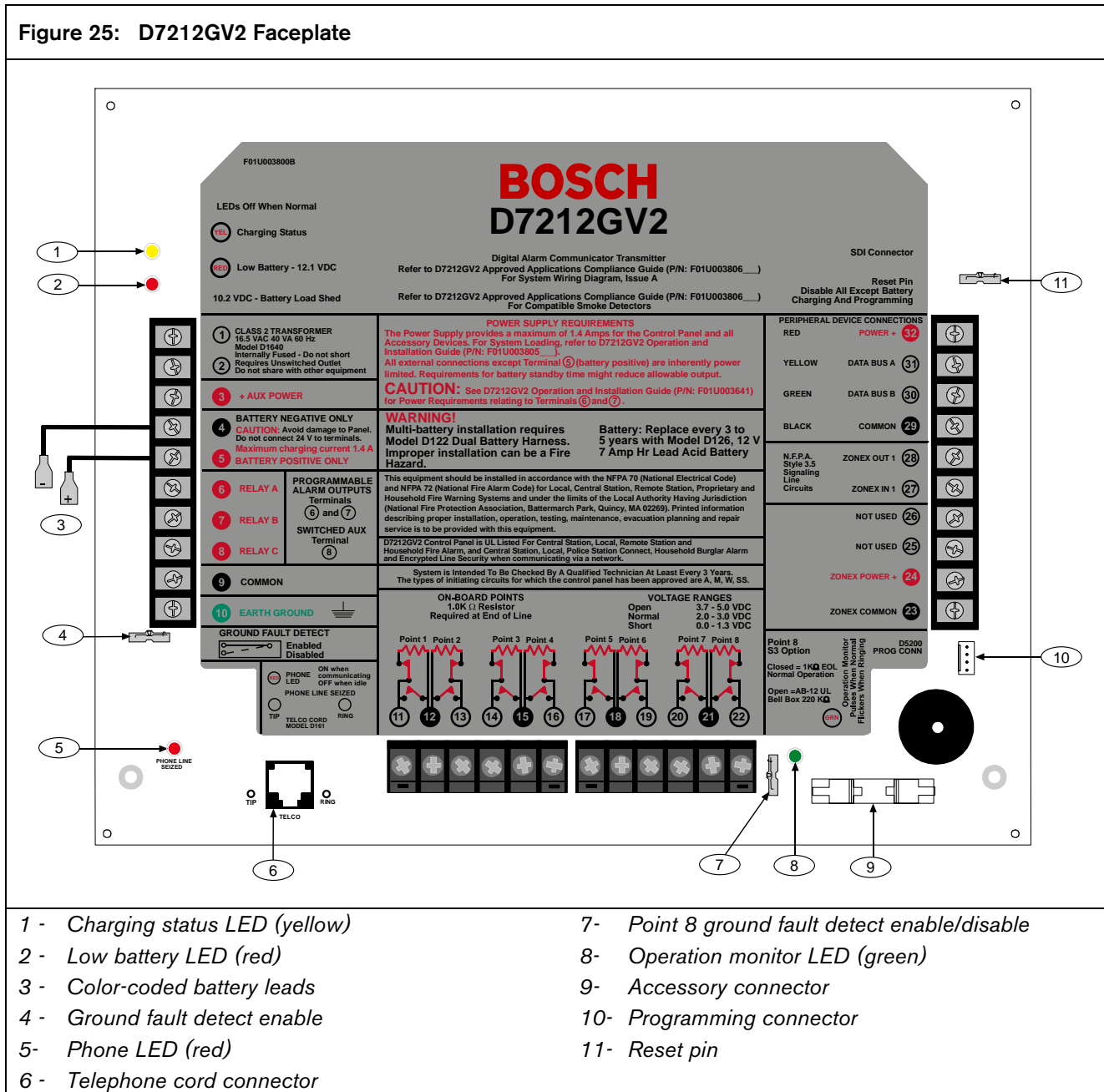

Appendix A: System Wiring Diagrams, Issue A

Figure 26: D7212GV2, Power Supply Side

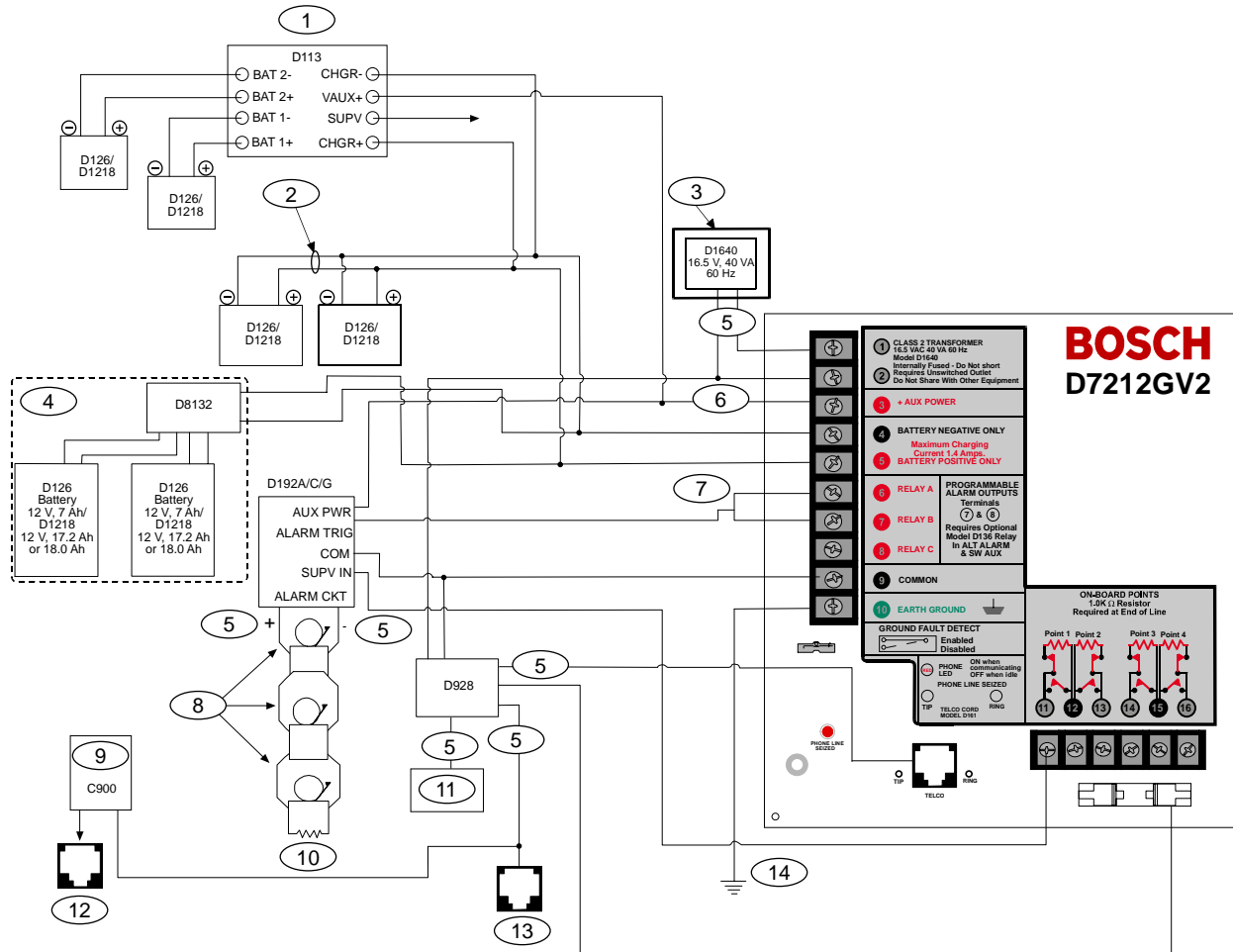

1 - If required by local AHJ, connect D113 Battery Lead Supervision Module.

2 - D122 Dual Battery Harness, as required.

3 - D1640 Transformer and D8004 Transformer Enclosure required for NFPA Applications

4 - D8132 Dual Battery Charger with two batteries (batteries are not supervised)

5 - Power limited, supervised

6 - Power limited

7 - To Relay A or Relay B

8 - Listed Audible Signaling Devices rated at 10.2 to 13.8 VDC (Do not use vibrating type horns.)

9- Optional

10- 560 Ω , 2 Ω EOL Resistor (P/N: 15-03130-005)

11- RJ31X, Secondary phone line

12- RJ31X, Jack

13- RJ31X, Primary phone line

14- To earth ground

Figure 27: D7212GV2, Input Points and Peripheral Devices

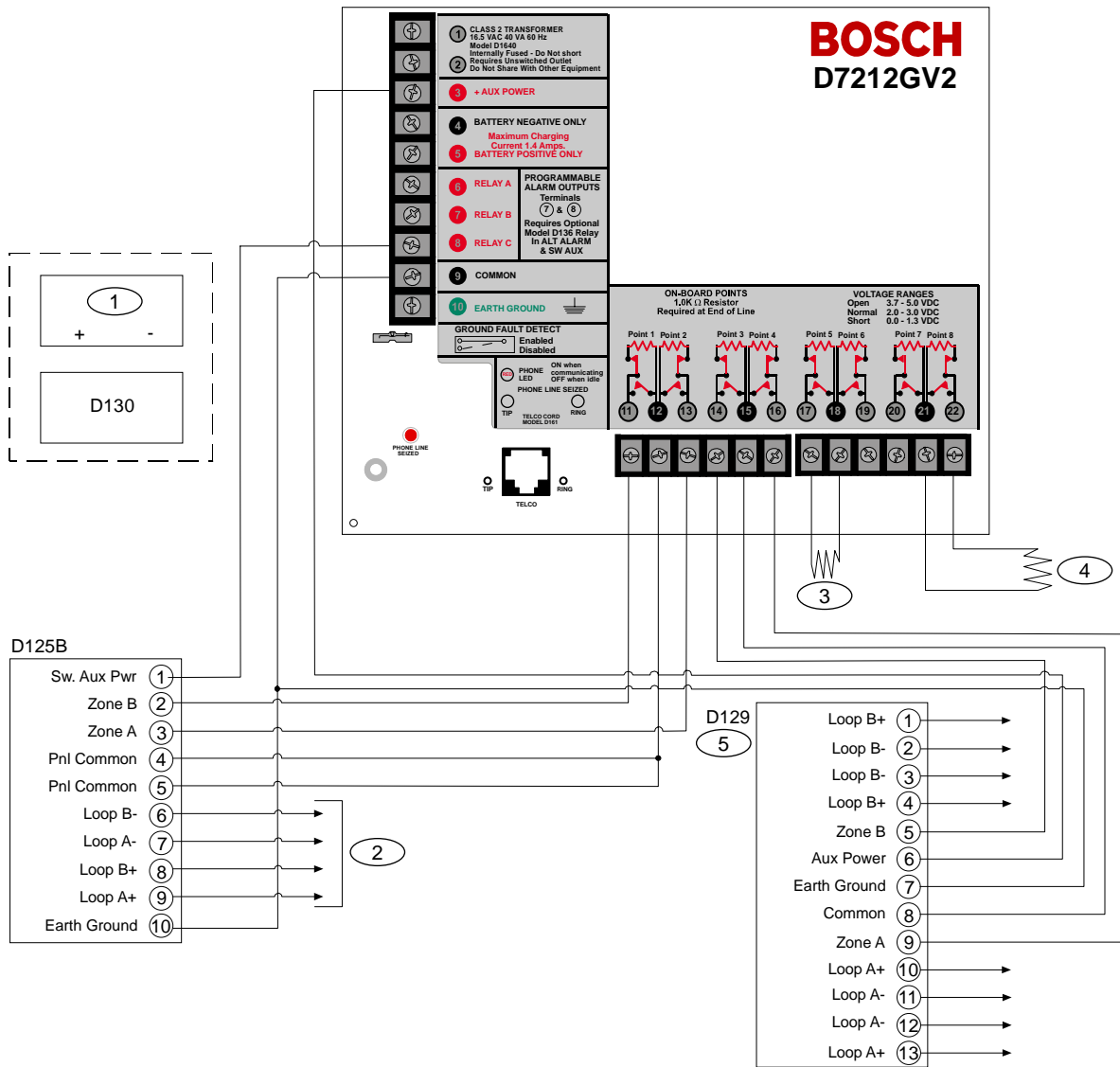

- 1 - (Optional): For 24 V applications, use a UL Listed 24 VDC power supply with a D130 Relay Module. Refer to the D130 Installation Instructions (P/N: 74-06262-000) for correct wiring requirements.
- 2 - To UL Listed two-wire smoke detectors. Refer to the 9000/G/GV2 Series Technical Service Note: UL Smoke Detector Compatibility (P/N: 33284) for a listing of compatible two-wire smoke detectors.
- 3 - P105 1 kΩ EOLR (P/N: 14-03130-004): Suitable for non-powered initiating and supervisory devices such as pull stations, heat sensors, and valve tampers.
- 4 - P105BL1 1kΩ EOLR (P/N: 14-0130-004): For typical burglar alarm applications.
- 5 - D129 provides optional Waterflow Retard feature. Not suitable for two-wire smoke detectors. (Note: Use Zero Retard except for waterflow devices.)



All external connections except Terminal 5 (battery positive) are power limited.

Figure 28: D7212GV2, SDI Devices

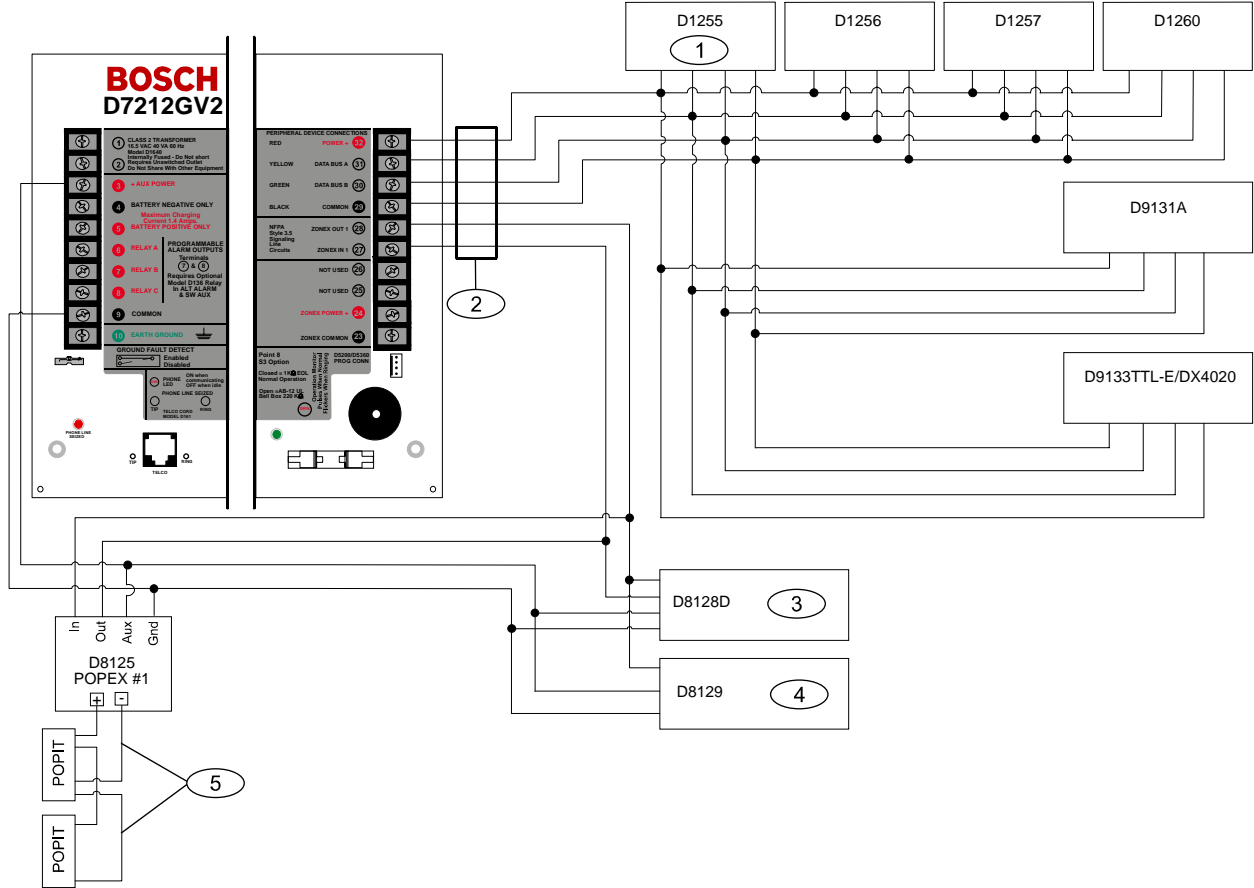

- | | |
|------------------------------------|---|
| 1 - Up to eight supervised | 4 - For Zone 1, up to three D8129s |
| 2 - Power limited, supervised | 5 - Up to 32 D9127U/I POPITs, or up to 32 D8127U/I POPITs |
| 3 - For Zone 1, up to four D8128Ds | |



All external connections except Terminal 5 (battery positive) are power limited.

Appendix B: Point Address Chart



Place the labels on the base of the POPIT. **Do not** attach labels to the POPIT cover.

A bullet (•) in the switch column indicates that the switch is set to ON.

Use D8127 or D9127 POPITs for Points 9 to 40. D8127 POPITs have DIP switches 1 to 6; D9127 POPITs have DIP switches 0 to 6.

Address	Switch						
	0	1	2	3	4	5	6
009	•	•	•	•	•	•	•
010	•	•	•	•	•	•	
011	•	•	•	•	•		•
012	•	•	•	•	•		
013	•	•	•	•		•	•
014	•	•	•	•		•	
015	•	•	•	•			•
016	•	•	•	•			
017	•	•	•		•	•	•
018	•	•	•		•	•	
019	•	•	•		•		•
020	•	•	•		•		
021	•	•	•			•	•
022	•	•	•			•	
023	•	•	•				•
024	•	•	•				
025	•	•		•	•	•	•
026	•	•		•	•	•	
027	•	•		•	•		•
028	•	•		•	•		
029	•	•		•		•	•
030	•	•		•		•	
031	•	•		•			•
032	•	•		•			
034	•	•			•	•	•
035	•	•			•	•	
036	•	•			•		•
037	•	•			•		
038	•	•				•	•
039	•	•				•	
040	•	•					•

Notes

Specifications

Table 23: Specifications			
Voltage Input (Power Supply)	Primary:	Terminals 1 and 2	16.5 VAC 40 VA class 2 plug-in transformer (D1640)
	Secondary:	Terminals 4 and 5	Sealed lead-acid rechargeable battery (12 VDC, 7 Ah or 12 VDC, 17.2 or 18 Ah). The control panel supports up to two 12 VDC, 7 Ah batteries using the D122 Dual Battery Harness or two D1218 (12 VDC, 17.2 or 18 Ah) batteries using a D122.
Current Requirements	Control Panel: Idle 200mA Alarm 500 mA Refer to the <i>Current Rating Chart for Standby Battery Calculations</i> section in the <i>D9412GV2/D7412GV2 Approved Applications Compliance Guide</i> (P/N: F01U003639) for the current draw requirements of other system components.		
Power Outputs*	All external connections are power-limited except battery terminals.		
	Continuous Power Outputs	Terminals 3, 24, and 32	1.4 A maximum at 10.2 VDC to 13.9 VDC (continuous supply) total for all devices and outputs supplied at Terminals 3, 24, and 32 and at the accessory and programming connectors.
	Alarm Power Output	Terminals 6 and 7	2.0 A maximum at 10.2 VDC to 13.9 VDC output. Output can be steady or one of three pulsed patterns depending on programming. Refer to <i>Relays</i> in the <i>D9412GV2/D7412GV2 Program Entry Guide</i> (P/N: F01U003636).
	Switched Aux Power	Terminal 8	1.4 A maximum at 10.2 VDC to 13.9 VDC output. Continuous output is interrupted by Sensor Reset or alarm verification depending on programming. Refer to <i>Relays</i> in the <i>D9412GV2/D7412GV2 Program Entry Guide</i> (P/N: F01U003636).
	Fire and Fire/Burglary Systems	To comply with UL 985 and 864 listing standards for fire alarm systems (effective March 1, 1989), the total combined continuous and alarm current draw for the system during alarm conditions must be limited to 1.4 A provided by the primary power supply (rectified AC). If current draw for the system exceeds 1.4 A, remove connected devices until the current draw falls below 1.4 A. Then, connect the removed devices to a D8132 Battery Charger Module or to an external power supply (refer to <i>Figure 19</i> on page 46).	
Minimum Operating Voltage	10.2 VDC		
SDI Bus	SDI Bus A (+):	9 VDC 4572 m (15000 ft) maximum	
	SDI Bus B (-):	9 VDC 4572 m (15000 ft) maximum	
Telephone Connections	Connection:	RJ31X or RJ38X jack can connect the control panels.	
	Two telco lines:	Bosch Security Systems D928 Dual Phone Line Module required for two phone line service. Supervision supplied by the control panel.	
Battery Discharge/Recharge Schedule	Discharge Cycle	13.9 VDC 13.8 VDC 12.1 VDC 10.2 VDC 10.0 VDC	Charging float level. Charging status LED on. Low Battery and AC Fail Reports if programmed. Low Battery LED on. Minimum operational voltage Battery load shed (processing functions continue if AC is present).
	Recharge Cycle	AC ON 13.7 VDC 13.9 VDC	Load shed relay resets, battery charging begins, Battery Trouble and AC Restoral Reports sent. Battery Restoral Report sent, Low Battery LED off. Charging status LED off, battery float charged.
Environmental	Temperature:	0°C to +50°C (+32°F to +122°F)	
	Relative Humidity:	Maximum 95% non-condensing	
Arming Stations	D720 Command Center, D1255 Command Center, D1256 Fire Command Center; D1257 Fire Alarm Annunciator; D1260 Alpha V Command Center; Keyswitch		
Point Thresholds	On-board Points 1 to 8	Open	Greater than 3.7 VDC, but less than 5.0 VDC.
		Normal	Greater than 2.0 VDC, but less than 3.0 VDC.
		Short	Greater than 0.0 VDC, but less than 1.3 VDC.
Compatible Enclosures	D8103 Universal Enclosure, D8109 Fire Enclosure, D8108A Attack Resistant Enclosure, BATB-40 Battery Box		

Notes

Bosch Security Systems, Inc.
130 Perinton Parkway
Fairport, NY 14450-9199
Customer Service: (800) 289-0096
Technical Support: (888) 886-6189

© 2005 Bosch Security Systems
F01U003805B



Recyclable

BOSCH